

FAULT ISOLATION IN LINEAR ANALOG CIRCUITS USING THE L_1 NORM

J.W. Bandler, Fellow, IEEE, R.M. Biernacki,
A.E. Salama, Student Member, IEEE, and J.A. Starzyk

Abstract

This paper deals with fault isolation in linear analog circuits under an insufficient number of independent voltage measurements. The L_1 norm is utilized in isolating the most likely faulty elements. Earlier work is extended by allowing measurements to be taken for more than a single excitation. An iterative procedure is followed in which we utilize linear programming as a powerful tool in solving the problem. Convergence is fast and the results of circuit examples subject to practical tolerances on components are much sharper than in our earlier method.

This work was supported by the Natural Sciences and Engineering Research Council of Canada under Grant A7239.

J.W. Bandler, A.E. Salama and J.A. Starzyk are with the Group on Simulation, Optimization and Control and the Department of Electrical and Computer Engineering, McMaster University, Hamilton, Canada L8S 4L7.

R.M. Biernacki is with, and J.A. Starzyk is on leave from, the Institute of Electronics Fundamentals, Technical University of Warsaw, Warsaw, Poland.

I. INTRODUCTION

With a sufficient number of independent measurements fault isolation is carried out by identifying all network components. There is usually a trade-off between the computational effort required and the number of accessible network nodes. When all the network nodes are accessible the components are identified by solving a system of linear equations [1,2]. If some of the network nodes are inaccessible a system of nonlinear equations [3] is usually solved for identifying the network components. Normally, not all the nodes are accessible and this will make the problem of fault isolation by identifying all network components computationally expensive and time consuming.

For a limited number of independent voltage measurements the identification of all network components is impossible and fault isolation is carried out by identifying the faulty components under the assumption that the changes in all good components are within their tolerances. Two approaches have been followed [4]. The first approach utilizes the measurements in constructing algebraic equations which are invariant on the changes in the faulty elements. The second approach utilizes an estimation criterion in isolating the most likely faulty set [4-6].

In this paper, we examine the use of the least-one-objective function in estimating the faulty elements. Mainly, we extend our previous study to the problem when more than one excitation is performed. This relaxation permits us to use more measurements from the available accessible nodes. An iterative procedure has to be followed, however, to find the faulty elements. In every iteration a linear programming problem is solved for the changes in the network components.

In what follows we present the formulation of the problem, the description of the iterative procedure and some examples to demonstrate the efficiency of this iterative approximate fault isolation method.

II. APPROXIMATE FAULT ISOLATION

Given a number of independent voltage measurements which is less than the total number of the components of the faulty network, it is required to estimate the most likely faulty elements. If we permit all the network components to change the aforementioned problem will have an infinite number of feasible solutions. Practically, the faulty components are very few in number and the relative change in their values is significantly larger than in the nonfaulty ones.

The change in a network component value from its nominal can be represented by either a current source or a voltage source which is in parallel or in series, with the component, respectively [4]. For a single excitation, the change in the performed voltage measurements from their nominal values due to the change in the values of the network components is given by

$$\Delta \underline{V}^m = \underline{H}^m \underline{e}, \quad (1)$$

where $\underline{e} \triangleq [e_1 \ e_2 \ \dots \ e_n]^T$ is the vector of the assumed sources that represent the changes in the n components from nominal and \underline{H}^m is the hybrid matrix that relates the changes in the measured voltages to the assumed sources \underline{e} . \underline{H}^m is computed directly using the nominal component values.

Every component of \underline{e} has the form

$$e_i = (j\omega)^{\alpha_i} \Delta p_i x_i = e_{1i} + j e_{2i}, \quad (2)$$

where $\omega_i = 0, 1$ or -1 depending on the component type, Δp_i is the change in component value and x_i is the actual controlling voltage or current for the component depending on whether e_i is a current or a voltage source, respectively. Normally, x_i is unknown unless a direct measurement of its value has been carried out.

Equation (1) is an underdetermined system of linear equations in the parameters \underline{e} . We construct the following linear optimization problem which can be easily solved using linear programming to find the most likely faulty components.

$$\text{Minimize } \sum_{i=1}^n (|e_{1i}| + |e_{2i}|) \quad (3a)$$

$\underline{e}_1, \underline{e}_2$

subject to

$$\Delta \underline{V}^m = \underline{H}^m (\underline{e}_1 + j \underline{e}_2), \quad (3b)$$

where \underline{e}_1 and \underline{e}_2 are the real and imaginary part of the vector \underline{e} , respectively.

The result of the optimization problem will provide us with the vector \underline{e} . Then the network is simulated using the original excitation and the vector \underline{e} to find $x_i, i = 1, \dots, n$. The change in every network component can be easily computed using equation (2). Comparing the change in every component with its allowed tolerance the faulty ones are readily isolated.

The formulation of the optimization problem in (3) does not destroy the linear relation in (1) and it does not create more unknowns since the unknown network response x_i is included in the error parameter (2). But, at the same time, for nonresistive networks it defines two error parameters for every component which cannot be easily correlated. Also

the formulation is restricted to a single excitation at any time since any new excitation will add $2n$ new error parameters.

Practically, we would like to have the system (1) less under-determined. This is achieved if we increase the number of measurements by exciting the network at more than one external node and/or using excitations at different frequencies. We then consider Δp_i as the error parameter.

In order to preserve the linear system (1), the network responses x_i , $i = 1, \dots, n$, have to be known. Hence, they are assumed and an iterative procedure updates their values and at the same time computes the changes in the component values.

For more than a single excitation, we consider the following optimization problem instead of (3).

$$\text{Minimize}_{\Delta p} \sum_{i=1}^n \left| \Delta p_i / p_i^0 \right| \quad (4a)$$

subject to

$$\begin{bmatrix} \Delta \tilde{V}^{m1} \\ \Delta \tilde{V}^{m2} \\ \vdots \\ \Delta \tilde{V}^{mk} \end{bmatrix} = \begin{bmatrix} \tilde{H}^{m1} \tilde{X}^{m1} \tilde{\Omega}^{m1} \\ \tilde{H}^{m2} \tilde{X}^{m2} \tilde{\Omega}^{m2} \\ \vdots \\ \tilde{H}^{mk} \tilde{X}^{mk} \tilde{\Omega}^{mk} \end{bmatrix} \Delta p, \quad (4b)$$

where $\Delta p \triangleq [\Delta p_1 \ \Delta p_2 \ \dots \ \Delta p_n]^T$ is the vector of the changes in components from nominal values, and for the ℓ th excitation, $\Delta \tilde{V}^{m\ell}$ is the change in the measured voltages from nominal, $\tilde{H}^{m\ell}$ is the hybrid matrix which relates the measured voltages to the assumed sources,

$$\tilde{X}^{m\ell} \triangleq \text{diag}[x_1^{m\ell}, x_2^{m\ell}, \dots, x_n^{m\ell}], \quad (5)$$

where $x_i^{m\ell}$ is the i th controlling branch voltage or current depending

whether the assumed source is a current or a voltage source, respectively, and

$$\tilde{z}^{m\ell} \triangleq \text{diag}[(j\omega_{m\ell})^{\alpha_1}, (j\omega_{m\ell})^{\alpha_2}, \dots, (j\omega_{m\ell})^{\alpha_n}], \quad (6)$$

defines the frequency dependency of the components. The normalization w.r.t. p_i^0 in (4a) is needed when the nominal values of the components are varied over a wide range.

Optimization problem (4) can be modified by adding the following inequality constraints

$$\Delta p_i > -p_i^x, \quad i = 1, \dots, n, \quad (7)$$

where p_i^x is the value of network element after being updated. Initially p_i^x is set to its nominal design value p_i^0 . These constraints are added to prevent any nonphysical solutions.

We utilize the measurements together with an updated model of the network to compute $\tilde{H}^{m\ell}$ and $\tilde{X}^{m\ell}$, $\ell = 1, \dots, k$. The responses $x_i^{m\ell}$, $\ell = 1, \dots, k$, $i = 1, \dots, n$ are functions of the nodal voltages. We update only the values of the internal node voltages since the external node voltages are known from measurements.

Algorithm

Step 1 Using the nominal component values construct the matrices required by (4).

Step 2 Solve the linear optimization problem (4) and update the network component values.

Step 3 If there is no appreciable change in the component values, stop.

Step 4 Recompute the matrices required by (4) using the updated network. Return to Step 2.

III. EXAMPLES

Example 1

Consider the resistive network shown in Fig. 1 with the nominal values of elements $G_i = 1$ and tolerances $\varepsilon_i = \pm 0.05$, $i = 1, 2, \dots, 20$. All outside nodes are assumed to be accessible with node 12 taken as the ground node. Nodes 4, 5, 8 and 9 are assumed internal where no measurements can be performed.

Two faults are assumed in the network in elements G_2 and G_{18} . For Case 1, we applied the fault isolation method with a single excitation at node 1 and simulated the voltages at the nodes 1, 2, 3, 6, 7, 10 and 11. We solved the optimization problem (3) for the error parameters \underline{g} . Then, the changes in the component values were computed. For Case 2, we considered two excitations applied at nodes 3 and 6 sequentially and performed voltage simulations from all available external nodes. We constructed optimization problem (4), and applied 3 iterations of our iterative procedure. See Table I for the results.

Both methods have identified the actual faulty elements, but in Case 2 the estimated changes in the faulty elements approach their true values. Some of the changes in the nonfaulty components have slightly exceeded their allowed tolerances, but these changes are small so we can still consider them nonfaulty.

Example 2

Consider the one stage transistor amplifier in Fig. 2 with its equivalent circuit in Fig. 3. This example was originally considered by Chen and Saeks in [7]. The nominal component values together with the actual values are listed in Table II. Three faults are assumed in the

network, namely, C_1 , $r_{\bar{n}}$ and g_m , with all other elements within their relative tolerances. We first applied optimization problem (3). A single current excitation is applied at node 1 of angular frequency 0.01 rad/sec. Voltage measurements are simulated at the assumed accessible nodes 1, 2, 4, 5 and 6. For optimization problem (4), we excited the network twice at node 1 using two different frequencies, namely, 0.01 rad/sec and 0.0075 rad/sec, and voltage measurements are obtained from the same accessible nodes. The results of both cases are given in Table II. Convergence in Case 2 occurred after 5 iterations. It is clear that the results of Case 2 are much sharper and they identify exactly the faulty elements.

IV. CONCLUSIONS

A method for approximate fault isolation is presented. We utilize the properties of the L_1 norm in isolating the most likely network components which have exhibited large changes in their values. This paper extends our earlier method [4] by allowing voltage measurements to be performed for more than one excitation of the faulty network. This obviously utilizes the available external nodes by obtaining more information about the network under test.

The formulation of the problem necessitates the application of an iterative procedure for its solution. A linear programming problem is solved in every iteration to provide us with the most likely changes in the network components. Linear programming is very efficient and from our experience with the proposed method the iterative procedure converges rapidly.

By adding more information about the network the problem becomes less underdetermined and the approximate fault isolation method is expected to provide sharper results. This is easily seen from the results of the examples considered in this paper.

Our approximate method can be used by itself for fault isolation, or we could verify the obtained results by constructing algebraic invariant equations corresponding to the detected faulty set as we did in [4].

REFERENCES

- [1] T.N. Trick, W. Mayeda and A.A. Sakla, "Calculation of parameter values from node voltage measurements", IEEE Trans. Circuits and Systems, vol. CAS-26, 1979, pp 466-474.
- [2] R.M. Biernacki and J.W. Bandler, "Postproduction parameter identification of analog circuits", Proc. IEEE Int. Symp. Circuits and Systems (Houston, TX, 1980), pp. 1082-1086.
- [3] N. Navid and A.N. Wilson, Jr., "A theory and an algorithm for analog circuit fault diagnosis", IEEE Trans. Circuits and Systems, vol. CAS-26, 1979, pp. 440-457.
- [4] J.W. Bandler, R.M. Biernacki and A.E. Salama, "A linear programming approach to fault location in analog circuits", Proc. IEEE Int. Symp. Circuits and Systems (Chicago, IL, 1981), pp. 256-261.
- [5] H.M. Merrill, "Failure diagnosis using quadratic programming", IEEE Trans. Reliability, vol. R-22, 1973, pp. 207-213.
- [6] M.N. Ransom and R. Saeks, "Fault isolation with insufficient measurements", IEEE Trans. Circuit theory, vol. CT-20, 1973, pp. 416-417.
- [7] H.S.M. Chen and R. Saeks, "A search algorithm for the solution of the multifrequency fault diagnosis equations", IEEE Trans. Circuits and Systems, vol. CAS-26, 1979, pp. 589-594.

TABLE I
RESULTS FOR EXAMPLE 1

Element	Nom. Value	Act. Value	Percentage Deviation		
			Actual	Case 1	Case 2
G ₁	1.0	0.98	-2.0	-4.15	- 2.20
G ₂	1.0	0.50	-50.0	-50.42	-47.86
G ₃	1.0	1.04	4.0	0.0	8.60
G ₄	1.0	0.97	-3.0	0.0	-2.46
G ₅	1.0	0.95	-5.0	0.0	-2.36
G ₆	1.0	0.99	-1.0	0.0	-0.14
G ₇	1.0	1.02	2.0	0.0	-2.49
G ₈	1.0	1.05	5.0	0.0	0.39
G ₉	1.0	1.02	2.0	0.0	0.84
G ₁₀	1.0	0.98	-2.0	0.0	-1.28
G ₁₁	1.0	1.04	4.0	0.0	0.0
G ₁₂	1.0	1.01	1.0	-3.06	1.55
G ₁₃	1.0	0.99	-1.0	0.0	0.0
G ₁₄	1.0	0.98	-2.0	0.0	2.47
G ₁₅	1.0	1.02	2.0	0.0	1.51
G ₁₆	1.0	0.96	-4.0	-7.07	-6.69
G ₁₇	1.0	1.02	2.0	0.0	1.91
G ₁₈	1.0	0.50	-50.0	-40.1	-46.90
G ₁₉	1.0	0.98	-2.0	-9.21	-3.38
G ₂₀	1.0	0.96	-4.0	-6.81	-6.14

TABLE II
RESULTS FOR EXAMPLE 2

Element	Nom. Value	Act. Value	Percentage Deviation		
			Actual	Case 1	Case 2
C_1	20.0	10.0	-50.0	-48.68	-50.0
R_s	75.0	76.92	2.56	0.0	-3.04
r_x	10.0	10.2	2.00	0.0	-2.06
r_π	40.0	66.67	66.66	-12.93	53.36
c_{π}	15.0	14.0	-6.66	0.0	6.62
c_μ	25.0	24.0	-4.00	-0.32	-4.12
g_m	10.0	5.0	-50.00	0.0*	-46.21
R_c	10.0	9.8	-2.00	-1.36	2.55
C_2	20.0	19.0	-5.00	-0.65	-5.59
R_L	20.0	20.6	3.0	1.43	-3.44
R_e	30.0	29.4	-1.96	4.97	1.37
C_e	10.0	9.5	-5.00	0.0	-5.01
R_1	10.0	10.05	0.5	-1.43	-0.50

* A faulty element has not been detected

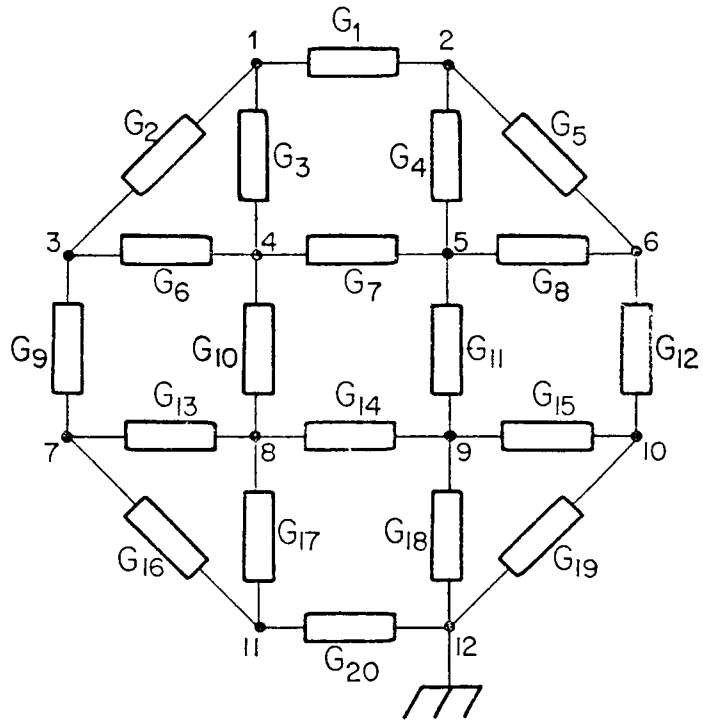

Fig. 1 The resistive network.

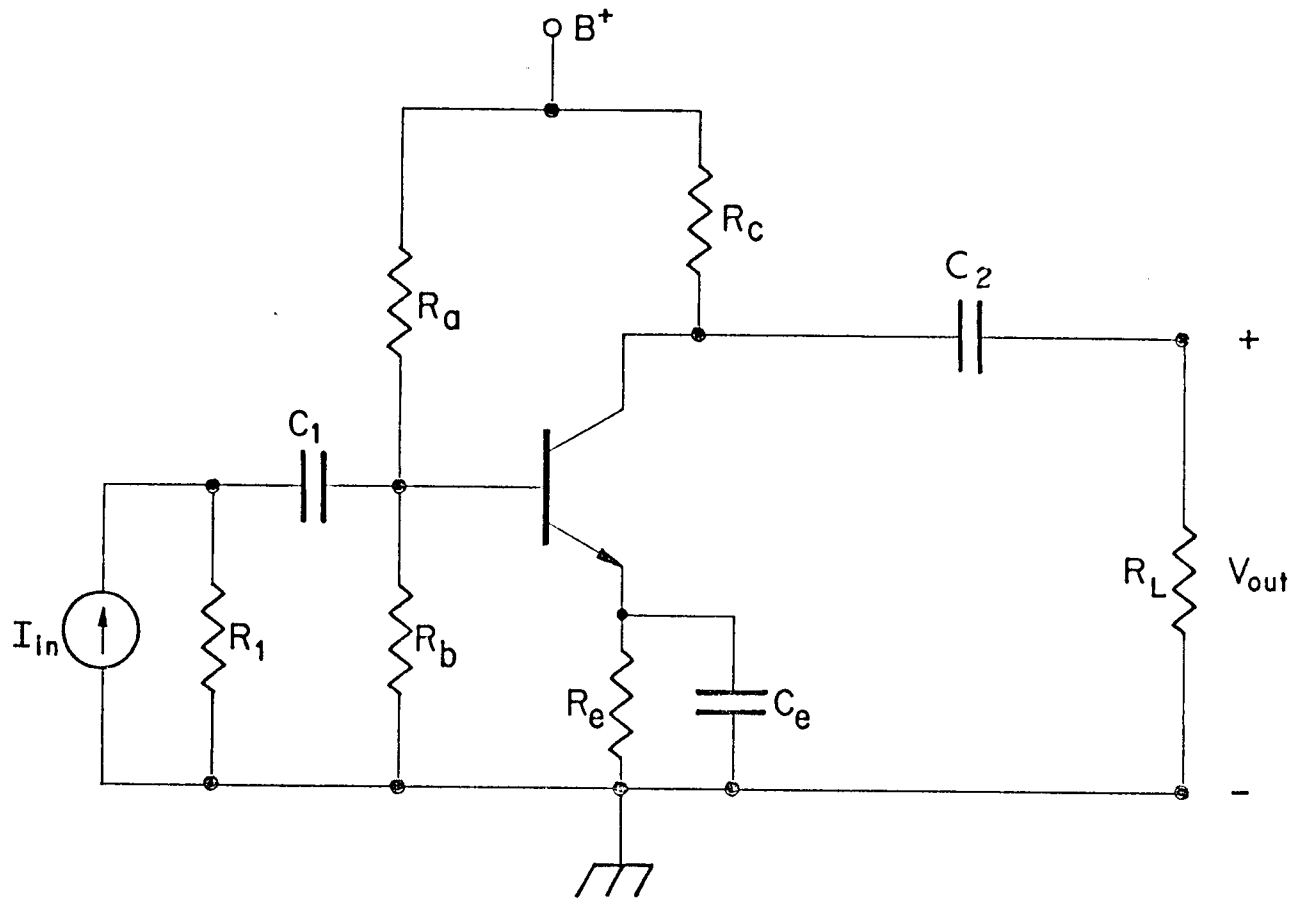

Fig. 2 The transistor amplifier circuit.

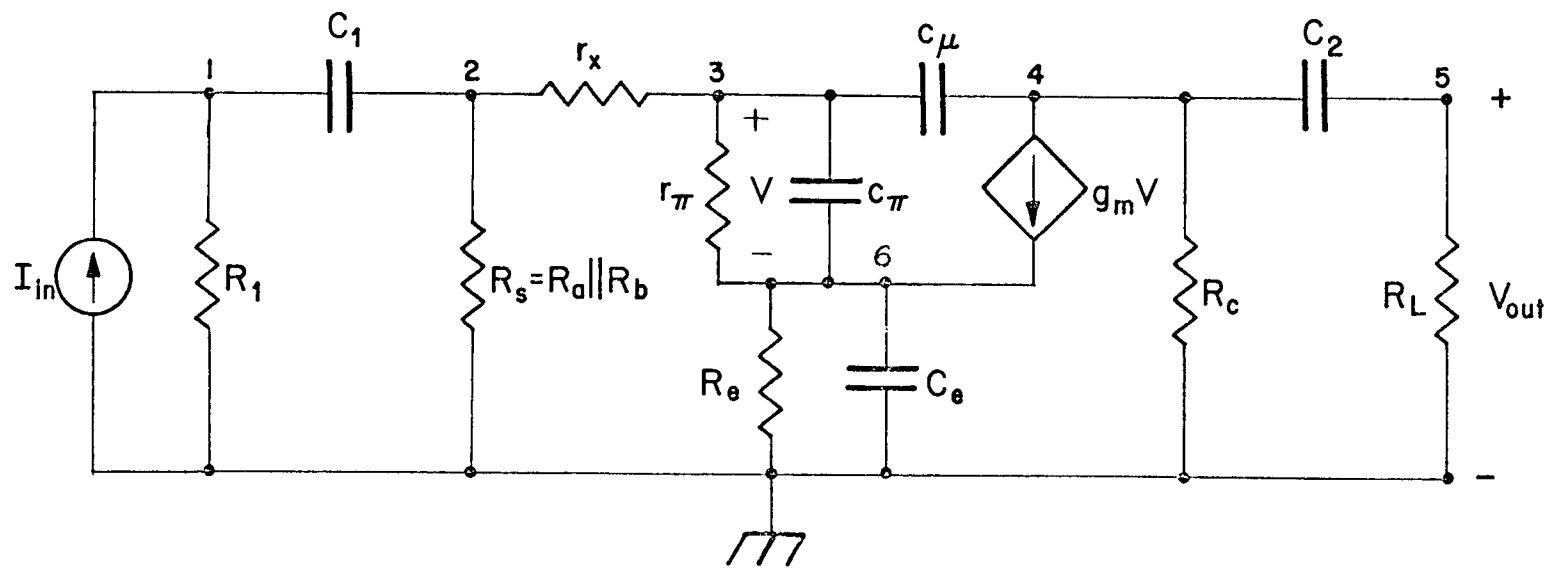

Fig. 3 The amplifier equivalent circuit.