

# Analog Methods for Computer-Aided Circuit Analysis and Diagnosis

*edited by*

Takao Ozawa

*Kyoto University  
Kyoto, Japan*

MARCEL DEKKER, INC.

New York and Basel

Copyright © 1988 by Marcel Dekker, Inc.



# 14

## Optimization Techniques for Modeling, Diagnosis, and Tuning

John W. Bandler and Qi-jun Zhang

*McMaster University  
Hamilton, Ontario, Canada*

### 1 INTRODUCTION

This chapter deals with the application of optimization techniques for modeling, diagnosis, and tuning (MDT) of electrical circuits. A conventional interpretation of such techniques for modeling and diagnosis is the determination of appropriate network parameters leading to the best match between circuit responses and measured data. When the measurements are insufficient to evaluate all network elements, the most likely faults may be located. Otherwise, if the measurements are sufficient, parameter identification is initiated, resulting in a circuit model whose performance best fits the measurement data in the presence of uncertainties and noise. Closely related is the tuning problem, which has been approached mostly from the optimization point of view. Existing software for mathematical programming can be readily exploited in this case.

Our presentation is tutorial but designed to be helpful for a state-of-the-art understanding. We first review circuit-oriented optimization methods with emphasis on aspects important in MDT. A general formulation of circuit diagnosis as an optimization problem is introduced. It is followed by a detailed investigation into three specific formulation cases. Optimization methods for modeling and tuning are presented and compared with those for diagnosis. Illustrative examples are provided.

## 2 CIRCUIT-ORIENTED OPTIMIZATION TECHNIQUES

Optimization methods have played an important role in computer-aided design of circuits and systems [1–9]. Recent advances in this area produced successful results that would have been prohibitively labor-intensive with other techniques [10]. Typical circuit design objectives are to satisfy or to exceed design specifications as much as possible. The MDT problems, however, are usually oriented either toward (response) data fitting or toward “parameter fitting” or a combination of both. The parameter fitting can be interpreted as forcing parameters to approach a desired pattern. Such a pattern is constructed to best represent

1. An estimation of the parameters, e.g., results from a deliberate perturbation of the circuit (for more measurement information), a projected target parameter point for tuning
2. An assumption of the circuit philosophy, e.g., type of faults, whether catastrophic or soft
3. A criterion for optimality, e.g., the objective for minimum parameter adjustment in tuning

### 2.1 Introduction to Mathematical Programming

An optimization problem can be stated as

$$\underset{\phi}{\text{minimize}} \quad U(\phi) \quad (1a)$$

subject to constraints

$$\mathbf{g}(\phi) \geq \mathbf{0} \quad (1b)$$

and

$$\mathbf{h}(\phi) = \mathbf{0} \quad (1c)$$

where  $\phi \triangleq [\phi_1 \quad \phi_2 \quad \cdots \quad \phi_n]^T$ ,  $\mathbf{g} \triangleq [g_1 \quad g_2 \quad \cdots \quad g_{n_g}]^T$ , and  $\mathbf{h} \triangleq [h_1 \quad h_2 \quad \cdots \quad h_{n_h}]^T$ .

When  $U$ ,  $\mathbf{g}$ , and  $\mathbf{h}$  are all linear functions of  $\phi$ , (1) is a linear programming (LP) problem, readily solvable by the simplex method [11], a classical approach being currently challenged by Karmarkar's algorithm [12, 13].

To handle the nonlinear programming (NLP) problem, i.e., the nonlinear case of (1), a variety of methods have been developed. The unconstrained NLP problem can be solved by conjugate direction methods and quasi-Newton methods. The constrained NLP problem can be handled using, e.g., penalty and barrier methods and augmented Lagrangian methods.

A systematic treatment of (1) can be found in many textbooks, e.g., Luenberger [11]. A comprehensive examination of optimization from

the circuit design point of view is provided in Refs. [1–9]. In this section, we highlight those aspects of optimization which are relevant to MDT.

### 2.2 Least $p$ th Optimization [14–16]

A frequently encountered objective  $U(\Phi)$  is the  $p$ th norm of  $\mathbf{f}(\Phi) \triangleq [f_1(\Phi) \ f_2(\Phi) \ \dots \ f_m(\Phi)]^T$ , that is,

$$U(\Phi) = \left( \sum_{i=1}^m |f_i(\Phi)|^p \right)^{1/p}, \quad p \geq 1 \tag{2}$$

The larger the value of  $p$ , the more emphasis is being put on  $\max\{|f_1|, |f_2|, \dots, |f_m|\}$ . At the solution, large (small)  $p$  typically produces many  $|f_i|$ 's that are equal to  $\max\{|f_1|, |f_2|, \dots, |f_m|\}$  (equal to zero).

The  $p = 1$  case of (2) corresponds to the  $l_1$  norm optimization, solvable by the two-stage algorithm of Hald and Madsen [17, 18]. The algorithm combines a first-order method that approximates the solution by successive linear programming with a quasi-Newton method that uses approximate second-order information to solve the system of nonlinear equations arising from the necessary first-order conditions at a solution.

The  $p = 2$  case of (2) (least-squares or  $l_2$  approximation) is a problem of wide publicity. Both first-order and second-order methods have been derived for general nonlinear  $l_2$  problems [19, 20]. For certain linear  $l_2$  problems, a closed-form solution is obtainable by invoking generalized matrix inversion [21, 22].

The objective function defined in (2) is used to penalize the modulus of  $f_i$ . To penalize the value of  $f_i$ , we use the generalized least  $p$ th function

$$U(\Phi) = \begin{cases} M_f \left( \sum_{i \in K} (f_i(\Phi)/M_f)^q \right)^{1/q} & \text{if } M_f \neq 0 \\ 0 & \text{if } M_f = 0 \end{cases} \tag{3}$$

where

$$M_f \triangleq \max_{i \in J} f_i(\Phi) \\ J \triangleq \{1, 2, \dots, m\} \tag{4}$$

and

$$\begin{aligned} \text{if } M_f > 0, \quad \text{then } K &= \{i | f_i \geq 0, i \in J\} & \text{and } q &= p \\ \text{if } M_f < 0, \quad \text{then } K &= J & \text{and } q &= -p \end{aligned} \tag{5}$$

In the case of  $M_f > 0$  ( $M_f < 0$ ), the larger the value of  $p$ , the more nearly would we expect the maximum (minimum)  $|f_i|$  to be emphasized. Therefore,

the minimization of (3) corresponds to the effort to meet (when  $M_f > 0$ ) or to exceed (when  $M_f < 0$ ) a design specification as much as possible.

As  $p \rightarrow \infty$ , the generalized least  $p$ th optimization approaches the minimax optimization, the latter being effectively solved by the combined LP and quasi-Newton method of Hald and Madsen [23, 24]. The algorithm is a two-stage one similar to the  $l_1$  optimization algorithm of [17]. Initially, stage 1 is used and at each point  $\mathbf{f}$  is approximated by linear functions using first-order information. In stage 2, the quasi-Newton iteration is used to solve a set of nonlinear equations that necessarily hold at a local minimum. Usually, stage 1 is used to obtain fast convergence to the neighborhood of the solution. Stage 2 is used to obtain superlinear final convergence, but several switches between the two stages may take place.

The two-stage algorithms for  $l_1$  and minimax optimizations are computationally practical and have been implemented by Bandler et al. [25, 26].

### 2.3 Quadratic Programming

In a quadratic programming (QP) problem, the objective function is defined as

$$U(\boldsymbol{\phi}) \triangleq \Lambda + \mathbf{s}^T \boldsymbol{\phi} + \frac{1}{2} \boldsymbol{\phi}^T \mathbf{H} \boldsymbol{\phi} \quad (6)$$

where  $\Lambda$  is a scalar,  $\mathbf{s}$  is an  $n$ -vector, and  $\mathbf{H}$  is an  $n \times n$  matrix.

The QP problems arise both in their own right and as subproblems within general nonlinear optimization methods. Typically, a QP problem is to minimize the function of (6) subject to linear equality and/or inequality constraints. Such a problem can be solved, e.g., using the iterative methods described by Gill and Murray [27, 28]. The linear inequality constraints are treated using the active-set methods, in which a prediction of the set of constraints that are active at the solution is maintained. This prediction is called the working set and is updated by adding or deleting constraints as the iterations proceed. By treating the working set as equality constraints, the constrained QP problem is transformed into an unconstrained one. The problem is relatively easy to solve if the original  $\mathbf{H}$  is positive definite [27].

For unconstrained QP problems, with  $\mathbf{H}$  as positive definite, the minimum can be uniquely located in a finite number of steps, using, e.g., Newton's method and the conjugate gradient method.

### 2.4 MINMAX and MINBOX Approaches in Linearization

Linearization is often used in solving nonlinear programming problems. Hachtel et al. [29] described the MINMAX and MINBOX approaches, where the range of the validity of a linear approximation is specified in the variable domain and the function domain, respectively. Used in nonlinear

minimax optimization, the MINMAX approach resembles the conventional way of locating the minimax point of linearized functions subject to a prescribed “box constraint” on  $\phi$ . The MINIBOX approach, on the other hand, either produces a smallest step  $\Delta\phi$  that achieves user-specified levels of improvement in  $\mathbf{f}$ , or states that the levels are infeasible.

## 2.5 Gradient and Nongradient Approaches

The use of exact gradient information  $\partial U/\partial\phi$  significantly improves the effectiveness of an optimization algorithm. The well-known adjoint network method developed by Director and Rohrer [30, 31] remains a powerful tool for sensitivity calculation. An equivalent but pure algebraic approach has also been studied [32, 33]. For special types of networks, e.g., branched cascaded networks, more effective methods can be derived [34].

Not infrequently, the gradient is difficult or even impossible to obtain. Approximate gradient methods have been developed, in addition to the direct search methods, which do not depend explicitly on evaluation or estimation of gradients. The theoretical background is the Broyden formula [11, 35], which utilizes function values to improve the gradient estimation as the optimization proceeds. This feature has been implemented in nonlinear  $l_1$  and minimax optimization packages [36].

## 3 GENERAL FORMULATION OF DIAGNOSIS AS OPTIMIZATION PROBLEMS

### 3.1 Introduction

The analog diagnosis techniques are described here using a single frequency measurement. Such a description offers both conceptual and notational simplicity. Particular mathematical manipulations required for multifrequency cases are illustrated whenever necessary.

Suppose from the circuit under test (CUT) we obtain a set of measurements represented by an  $n_F$ -vector  $\mathbf{F}^M$ . The corresponding responses as functions of circuit parameters  $\phi \triangleq [\phi_1 \ \phi_2 \ \cdots \ \phi_n]^T$  are given by  $\mathbf{F} \triangleq \mathbf{F}(\phi, \omega)$ . For single-frequency cases,  $\mathbf{F} \triangleq \mathbf{F}(\phi)$  is used for notational convenience. A nominal design of the circuit is characterized by  $\phi^0$  and  $\mathbf{F}^0$ .

When the measurements are insufficient to identify all parameters, e.g., when  $n_F < n$ , the equation

$$\mathbf{F}^M = \mathbf{F}(\phi^0 + \Delta\phi) \quad (7)$$

is an underdetermined one. An optimization technique can be used to find the most likely  $\Delta\phi$  among an infinite number of solutions to (7). Such a problem

can be stated as

$$\underset{\Delta\phi}{\text{minimize}} U(\Delta\phi) \quad (8a)$$

$$\text{s.t. } \mathbf{h}(\mathbf{F}^M, \Delta\phi) \triangleq \mathbf{F}(\phi^0 + \Delta\phi) - \mathbf{F}^M = \mathbf{0} \quad (8b)$$

where  $U$  is an increasing function of  $|\Delta\phi_i|$ ,  $i = 1, 2, \dots, n$ .

A convenient approach to solving (8) is to use penalty methods. For example, a least  $p$ th formulation is

$$\underset{\Delta\phi}{\text{minimize}} \left( \sum_{i=1}^n w_i |\Delta\phi_i|^p + \sum_{i=1}^{n_F} \beta_i |F_i(\phi^0 + \Delta\phi) - F_i^M|^p \right)^{1/p} \quad (9)$$

where  $w_i$ ,  $i = 1, 2, \dots, n$ , and  $\beta_i$ ,  $i = 1, 2, \dots, n_F$ , are appropriate weighting factors [25].

### 3.2 Constraint Equation

Suppose the  $N$ -node circuit is characterized by its nodal equation

$$\mathbf{YV} = \mathbf{I} \quad (10)$$

where  $\mathbf{Y}$ ,  $\mathbf{V}$ , and  $\mathbf{I}$  are the nodal admittance matrix, voltage vector, and current excitation vector, respectively. We assume, for convenience, that the measurable responses of the CUT, namely  $\mathbf{F}$ , can be represented by linear combinations of nodal voltages using an  $N \times n_F$  matrix  $\mathbf{C}$  such that

$$\mathbf{F} = \mathbf{C}^T \mathbf{V} \quad (11)$$

Thus,

$$\mathbf{F} = \mathbf{F}(\phi) = \mathbf{C}^T [\mathbf{Y}(\phi)]^{-1} \mathbf{I} \quad (12)$$

To simplify the nonlinear optimization of (8) and (9), researchers have employed two effective formulations, transforming the constraint equation into linear forms by introducing intermediate parameters. These formulations are the current/voltage source substitution model and the component connection model. The former model will be used throughout this chapter. A comprehensive treatment of the latter can be found in Refs. [37–39].

### 3.3 The Current/Voltage Source Substitution Model [40–45]

Changes in element values can be equivalently characterized by current or voltage sources. Figure 14.1 shows equivalent representations for some typical elements in linear circuits. Without loss of generality, we assume that the changes are represented by current sources only. Let  $\Delta \mathbf{I}^b$  be an  $n$ -vector containing such sources corresponding to the  $n$  variable elements and  $\mathbf{Q}$  be



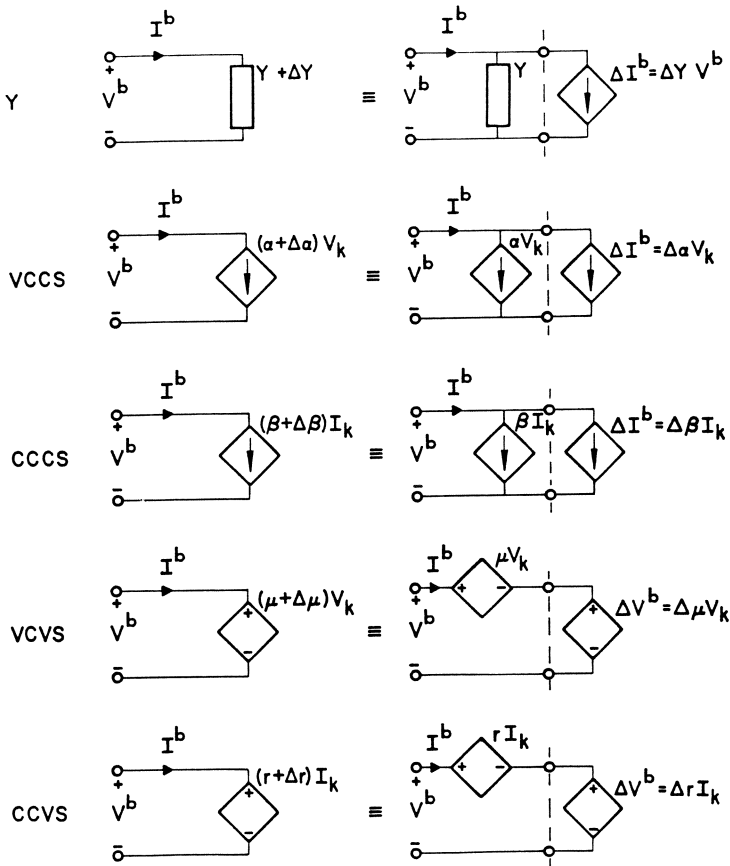

**Figure 14.1** Equivalent representation of changes in element values.

an  $N \times n$  incidence matrix relating the  $n$  branches containing variables to the  $N$  nodes of the circuit. By invoking the superposition theorem, we may write

$$\mathbf{Y}(\phi^0)\Delta\mathbf{V} = -\mathbf{Q}\Delta\mathbf{I}^b \tag{13}$$

where  $\Delta\mathbf{V}$  is the deviation of actual nodal voltages from their nominal values. Also,

$$\Delta\mathbf{F} \triangleq \mathbf{F} - \mathbf{F}^0 = \mathbf{C}^T\Delta\mathbf{V} = -\mathbf{C}^T[\mathbf{Y}(\phi^0)]^{-1}\mathbf{Q}\Delta\mathbf{I}^b \tag{14}$$

Denote

$$\mathbf{A}' \triangleq -\mathbf{C}^T[\mathbf{Y}(\phi^0)]^{-1}\mathbf{Q} \tag{15}$$

Then we have the constraint equation in linear form as

$$\mathbf{A}'\Delta\mathbf{I}^b = \mathbf{F}^M - \mathbf{F}^0 \quad (16)$$

or in real form as

$$\mathbf{A}\mathbf{x} = \mathbf{b} \quad (17)$$

where

$$\mathbf{A} = \begin{bmatrix} \text{Re}(\mathbf{A}') & -\text{Im}(\mathbf{A}') \\ \text{Im}(\mathbf{A}') & \text{Re}(\mathbf{A}') \end{bmatrix} \quad (18)$$

$$\mathbf{b} = [\text{Re}(\mathbf{F}^M - \mathbf{F}^0)^T \quad \text{Im}(\mathbf{F}^M - \mathbf{F}^0)^T]^T \quad (19)$$

and

$$\mathbf{x} = [\text{Re}(\Delta\mathbf{I}^b)^T \quad \text{Im}(\Delta\mathbf{I}^b)^T]^T \quad (20)$$

To compute  $\Delta\phi$  from  $\mathbf{x}$ , we simulate the network with all components held at nominal values and with additional current excitations  $\Delta I_i^b = x_i + jx_{i+n}$ ,  $i = 1, 2, \dots, n$ , connected across corresponding components. After measuring or calculating branch voltages  $V_i^b$ ,  $i = 1, 2, \dots, n$ , the component change is evaluated as

$$\Delta\phi_i = \frac{x_i + jx_{i+n}}{V_i^b} (j\omega)^{-\alpha}, \quad i = 1, 2, \dots, n \quad (21)$$

where  $\alpha \equiv \alpha_i$ , whose value can be 0, 1, or  $-1$  depending on whether the  $i$ th component is resistive, capacitive, or inductive [40, 41].

For multifrequency diagnosis, we use  $\Delta\phi$  as optimization variables directly.  $\mathbf{A}$ ,  $\mathbf{b}$ , and  $\mathbf{x}$  are redefined accordingly. For example,

$$\mathbf{A}_i = -\mathbf{C}^T[\mathbf{Y}(\phi^0, \omega_i)]^{-1}\mathbf{Q} \text{diag} \{(j\omega_i)^{\alpha_1} V_1^b(\omega_i), \quad (22)$$

$$(j\omega_i)^{\alpha_2} V_2^b(\omega_i), \quad \dots, \quad (j\omega_i)^{\alpha_n} V_n^b(\omega_i)\}$$

$$i = 1, 2$$

$$\mathbf{A}'' = \begin{bmatrix} \mathbf{A}_1 \\ \mathbf{A}_2 \end{bmatrix}, \quad \mathbf{b}'' = \begin{bmatrix} \mathbf{F}^M(\omega_1) - \mathbf{F}^0(\omega_1) \\ \mathbf{F}^M(\omega_2) - \mathbf{F}^0(\omega_2) \end{bmatrix} \quad (23)$$

$$\mathbf{A} = \begin{bmatrix} \text{Re}(\mathbf{A}'') \\ \text{Im}(\mathbf{A}'') \end{bmatrix}, \quad \mathbf{b} = \begin{bmatrix} \text{Re}(\mathbf{b}'') \\ \text{Im}(\mathbf{b}'') \end{bmatrix} \quad (24)$$

and

$$\mathbf{x} = \Delta\phi \quad (25)$$

where we have assumed that two frequency points are taken. The branch voltages  $V_k^b(\omega_i)$ ,  $k = 1, 2, \dots, n$ , are initially assumed. An iterative procedure updates  $V_k^b(\omega_i)$  and at the same time computes the changes in  $\phi$  [41].

If the nodal equation of (10) is replaced by a hybrid equation, a more general form of (17) can be similarly deduced where both current and voltage sources exist for an equivalent representation of  $\Delta\phi$  [40, 41].

### 3.4 The Component Connection Model [37–39]

We assume that the system topology is described by a matrix relation

$$\begin{bmatrix} \mathbf{u}' \\ \mathbf{F} \end{bmatrix} = \begin{bmatrix} \mathbf{L}_{11} & \mathbf{L}_{12} \\ \mathbf{L}_{21} & \mathbf{0} \end{bmatrix} \begin{bmatrix} \mathbf{v} \\ \mathbf{u} \end{bmatrix} \tag{26}$$

Here,  $\mathbf{u}'$  and  $\mathbf{v}$  are the component input and output variables, respectively, related by

$$\mathbf{v} = \mathbf{Z}\mathbf{u}' \tag{27}$$

where  $\mathbf{Z}$  is the component parameter matrix. The  $\mathbf{u}$  and  $\mathbf{F}$  in (26) are the system input and output variables related using the system matrix  $\mathbf{\Gamma}$  as

$$\mathbf{F} = \mathbf{\Gamma}\mathbf{u} \tag{28}$$

By introducing intermediate variables  $\mathbf{R}$ , we have the linear relation

$$\mathbf{\Gamma} = \mathbf{L}_{21}\mathbf{R}\mathbf{L}_{12} \tag{29}$$

where  $\mathbf{R}$  is related to  $\mathbf{Z}$ , using

$$\mathbf{R} = (\mathbf{1} - \mathbf{Z}\mathbf{L}_{11})^{-1}\mathbf{Z} \tag{30}$$

It has been shown [39] that for small changes in  $\mathbf{Z}$ ,

$$\Delta\mathbf{Z} \approx \Delta\mathbf{R} \tag{31}$$

As such,  $\mathbf{R}$  can be used instead of  $\mathbf{Z}$  for optimization. Final results for  $\mathbf{Z}$  can be computed using either the exact [i.e., deduced from (30)] or the approximate [i.e., deduced from (31)] relation between  $\mathbf{R}$  and  $\mathbf{Z}$ .

### 3.5 General Formulation

The intermediate variables  $\mathbf{x}$  defined in (20) exhibit a similar pattern to the parameters  $\Delta\phi$ , since an equivalent source current  $\Delta I^b$  increases as the corresponding  $\Delta\phi$  increases. Also,  $\Delta I^b = 0$  if and only if  $\Delta\phi = 0$ . Now, we can solve the optimization problem with  $\mathbf{x}$  as variables and use the solution to find  $\Delta\phi$ . A simple yet reasonable objective function is the least  $p$ th function of

x. A general formulation of diagnosis as an optimization problem is

$$\underset{\mathbf{x}}{\text{minimize}} U(\mathbf{x}) \triangleq \left( \sum_{i=1}^{2n} w_i |x_i|^p \right)^{1/p} \quad (32a)$$

$$\text{s.t. } \mathbf{Ax} - \mathbf{b} = \mathbf{0} \quad (32b)$$

where  $w_i$ ,  $i = 1, 2, \dots, 2n$ , are weighting factors and the constraint (32b) is derived from (17)–(20). For the multifrequency case, (22)–(25) can be used to define  $\mathbf{A}$ ,  $\mathbf{b}$ , and  $\mathbf{x}$  for the constraint equation (32b). In this case, the objective function  $U$  is the weighted least  $p$ th function of  $x_i$ ,  $i = 1, 2, \dots, n$ . After solving (32),  $\Delta\phi$  can be found using (21) or (25).

#### 4 DIAGNOSIS USING THE LEAST-SQUARES METHOD

The diagnosis technique using least-squares optimization was suggested by Ransom and Saeks [39]. It is based on the assumption that the catastrophic faults have been eliminated and the circuit failure is due to components drifting out of tolerance (as from age, temperature changes, etc.) [39, 42].

The optimization problem can be stated as

$$\underset{\mathbf{x}}{\text{minimize}} U(\mathbf{x}) \triangleq \mathbf{x}^T \mathbf{W} \mathbf{x} \quad (33a)$$

$$\text{s.t. } \mathbf{Ax} - \mathbf{b} = \mathbf{0} \quad (33b)$$

where the constraint equation (33b) is defined consistently with (32b).  $\mathbf{W}$  is a diagonal matrix containing weighting factors  $w_i$ ,  $i = 1, 2, \dots, 2n$ . An appropriate choice of the weightings can be such that the  $U$  of (33a) approximates

$$\sum_{i=1}^n \Delta\phi_i^2$$

under the assumption that  $\Delta\phi_i$ ,  $i = 1, 2, \dots, n$ , are quite small. For example [42], for  $1 \leq i \leq n$ ,

$$w_i = \frac{1}{2} (\text{Re}[(j\omega)^{\alpha_i} V_i^b])^{-2}$$

$$w_{i+n} = \frac{1}{2} (\text{Im}[(j\omega)^{\alpha_i} V_i^b])^{-2} \quad (34)$$

The solution of the  $l_2$  problem is directly obtained using generalized matrix inversion [21, 22], e.g.,

$$\mathbf{x} = \mathbf{W}^{-1} \mathbf{A}^T (\mathbf{A} \mathbf{W}^{-1} \mathbf{A}^T)^{-1} \mathbf{b} \quad (35)$$

Such a technique using a component connection model has been presented in [39]. The variables  $\mathbf{x}$  consist of elements of the matrix  $\Delta\mathbf{R}$ . The optimization problem is to minimize the  $l_2$  norm of  $\Delta\mathbf{R}$  subject to

$$\Delta\Gamma = \mathbf{L}_{21}\Delta\mathbf{R}\mathbf{L}_{12} \tag{36}$$

where  $\Delta\Gamma$  is the difference between the measured values and the nominal values of  $\Gamma$ . The solution is the generalized inverse of the matrix in (36) [21, 22]. The component connection model is effective here since  $\Delta\mathbf{R} \approx \Delta\mathbf{Z}$  under the assumption that no parameters have a significant deviation from nominal.

### 5 DIAGNOSIS USING THE QUADRATIC PROGRAMMING METHOD

The quadratic programming technique for diagnosis was suggested by Merrill [46]. He considered such a class of situations where a system becomes inoperative due to the failure of one or a few components. He pointed out that because the individual system components are generally highly reliable and well maintained, a diagnosis that implicates many components as having failed is probably not correct. Therefore, contrary to the  $l_2$  optimization technique, the main assumption here is that the difference between the actual and the nominal values for a few elements, which correspond to the faulty elements, is much greater than that for the remaining elements that are nonfaulty.

The optimization problem can be described as

$$\underset{\mathbf{x}}{\text{minimize}} U(\mathbf{x}) \triangleq \sum_{i=1}^{2n} w_i \sqrt{|x_i| + \delta} \tag{37a}$$

$$\text{s.t. } \mathbf{Ax} - \mathbf{b} = \mathbf{0} \tag{37b}$$

where the constraint equation (37b) is defined consistently with (32b). The  $\delta$  under the radical prevents the derivative of the objective function from becoming unbounded.

To solve (37) efficiently, Merrill put the constraint (37b) into the objective function in a quadratic form as a penalty term, applied uniform weightings  $w_i = 1, i = 1, 2, \dots, 2n$ , and transformed the problem into

$$\underset{\mathbf{y}}{\text{minimize}} U(\mathbf{y}) \triangleq \sum_{i=1}^{4n} \sqrt{y_i + \delta} + \frac{1}{2} \beta (\bar{\mathbf{A}}\mathbf{y} - \mathbf{b})^T (\bar{\mathbf{A}}\mathbf{y} - \mathbf{b}) \tag{38a}$$

$$\text{s.t. } \mathbf{y} \geq \mathbf{0} \tag{38b}$$

where  $\bar{\mathbf{A}} \triangleq [\mathbf{A} \quad -\mathbf{A}]$  and  $\mathbf{y}$  is a  $4n$ -vector related to  $\mathbf{x}$  via

$$\begin{aligned} y_i = x_i \quad \text{and} \quad y_{2n+i} = 0 \quad & \text{if } x_i \geq 0 \\ y_i = 0 \quad \text{and} \quad y_{2n+i} = -x_i \quad & \text{if } x_i < 0 \end{aligned} \tag{39}$$

$$i = 1, 2, \dots, 2n$$

Also,  $\mathbf{x}$  can be calculated from  $\mathbf{y}$  using

$$x_i = y_i - y_{2n+i}, \quad i = 1, 2, \dots, 2n \quad (40)$$

Furthermore, the square-root portion of  $U(\mathbf{y})$  is linearized at  $\mathbf{y} = \mathbf{y}^j$ , resulting in

$$U_j(\mathbf{y}) = \Lambda + \mathbf{s}^T \mathbf{y} + \frac{1}{2} \mathbf{y}^T \mathbf{H} \mathbf{y} \quad (41)$$

where

$$\mathbf{s} = \frac{1}{2} [(y_1^j + \delta)^{-1/2} \quad (y_2^j + \delta)^{-1/2} \quad \dots \quad (y_{4n}^j + \delta)^{-1/2}]^T - \beta \bar{\mathbf{A}}^T \mathbf{b} \quad (42)$$

and

$$\mathbf{H} = \beta \begin{bmatrix} \mathbf{A}^T \mathbf{A} & -\mathbf{A}^T \mathbf{A} \\ -\mathbf{A}^T \mathbf{A} & \mathbf{A}^T \mathbf{A} \end{bmatrix} \quad (43)$$

The scalar  $\Lambda$  is also a function of  $\beta$ ,  $\delta$ ,  $\mathbf{y}^j$ , and  $\mathbf{b}$ , but as its value is irrelevant to the minimization of  $U_j(\mathbf{y})$ , it will never actually have to be calculated.

As Merrill indicated, the use of variables  $\mathbf{y}$ , instead of  $\mathbf{x}$ , can eliminate the difficulty of derivative discontinuity of  $U$  at  $x_i = 0$ . The quasi-linearization of  $U$  from (38a) to  $U_j$  of (41) leads to the natural application of powerful quadratic programming methods [27]. The optimization problem of (38) is solved iteratively by the following steps.

- Step 1*      $j = 0$ ,  $\mathbf{y}^j = \mathbf{0}$ .  
*Step 2*     Compute  $\mathbf{s}$  as a function of  $\mathbf{y}^j$  using (42).  
*Step 3*     Minimize  $U_j(\mathbf{y})$  of (41), subject to  $\mathbf{y} \geq \mathbf{0}$ , using the quadratic programming method [27]. The solution is defined as  $\mathbf{y}^{j+1}$ .  
*Step 4*     If  $U(\mathbf{y}^{j+1}) \approx U(\mathbf{y}^j)$ , then calculate  $\mathbf{x}$  using (40) and stop; otherwise,  $j \leftarrow j + 1$  and go to step 2.

## 6 DIAGNOSIS USING THE LINEAR PROGRAMMING METHOD

Bandler et al. proposed the diagnosis technique using the  $l_1$  norm optimization [40, 41]. The main assumption is similar to that for the quadratic programming approach. However, instead of solving a sequence of quadratic optimization problems, a linear programming problem is formulated, taking advantage of the nature of the  $l_1$  norm as well as the linearity of the constraint equation. A solution to such a problem tends to satisfy the constraint with a minimum number of parameters different from zero. This is consistent with the assumption that a few elements are actually faulty [42, 43].

The optimization problem can be expressed as

$$\underset{\mathbf{x}}{\text{minimize}} U(\mathbf{x}) \triangleq \sum_{i=1}^{2n} w_i |x_i| \tag{44a}$$

$$\text{s.t. } \mathbf{Ax} - \mathbf{b} = \mathbf{0} \tag{44b}$$

where the constraint equation (44b) is defined consistently with (32b).

Such a problem can be solved directly using  $l_1$  optimization algorithms, e.g., [17, 25]. It can also be handled by using a regular linear programming solver in a manner similar to that in [47]. Let  $\mathbf{y}$  be defined by (39). The problem of (44) is transformed into a standard LP problem as

$$\underset{\mathbf{y}}{\text{minimize}} U(\mathbf{y}) \triangleq [w_1 \ w_2 \ \cdots \ w_{2n} \ w_1 \ w_2 \ \cdots \ w_{2n}] \mathbf{y} \tag{45a}$$

$$\text{s.t. } [\mathbf{A} \quad -\mathbf{A}] \mathbf{y} = \mathbf{b} \tag{45b}$$

$$\mathbf{y} \geq \mathbf{0} \tag{45c}$$

At the solution of (45),  $\mathbf{x}$  can be calculated from (40).

## 7 MODELING USING OPTIMIZATION METHODS

In a modeling problem, it is required to find parameter values of an equivalent device model to best fit measurement data. As Hachtel et al. have described [29, 48], the problem is of a type that is frequently encountered by product assurance engineers. These engineers are faced with the fact that the circuits which come off the product line differ from the circuits designed with circuit simulation programs. Consequently, they need device models that agree with on-chip measurements in order to estimate the statistics of the on-chip circuit performance.

### 7.1 Basic Formulation

Let  $\mathbf{f} = \mathbf{f}(\boldsymbol{\phi})$  be an  $m$ -vector containing the weighted difference between calculated response  $\mathbf{F}(\boldsymbol{\phi}, \omega)$  and measured data  $\mathbf{F}^M(\omega)$  in the form

$$w_i(\omega_j)(F_i(\boldsymbol{\phi}, \omega_j) - F_i^M(\omega_j)), \quad i \in \{1, 2, \dots, n_F\}, j \in \{1, 2, \dots, n_\omega\} \tag{46}$$

Due to measurement errors and nonideal effects,  $\mathbf{f} = \mathbf{0}$  may not be possible. Therefore, the modeling problem can be stated as

$$\underset{\boldsymbol{\phi}}{\text{minimize}} U(\boldsymbol{\phi}) \tag{47a}$$

$$\text{s.t. } \boldsymbol{\phi}_L \leq \boldsymbol{\phi} \leq \boldsymbol{\phi}_U \tag{47b}$$

where  $U$  is an increasing function of  $|f_i(\phi)|$ ,  $i = 1, 2, \dots, m$ .  $\phi_L$  and  $\phi_U$  are lower and upper bounds, respectively, for  $\phi$ .

A reasonable objective function  $U(\phi)$  can be the least  $p$ th function of  $f(\phi)$  in the form of (2).

With a small value of  $p$ , the objective function tends to accommodate measurements that may contain accidental large errors. Large values of  $p$  produce satisfactory results when all measurement errors and nonideal effects are small. Successfully implemented algorithms have used  $p = 1$  [25],  $p = 2$  [49, 50], and  $p = \infty$  [29, 48].

## 7.2 Limitations of the Basic Formulation

The basic formulation of modeling problems is a traditional approach that is almost entirely directed at achieving the best possible match between measured and calculated responses. This approach has serious shortcomings in two frequently encountered cases. The first case is when the equivalent circuit parameters are not unique with respect to the responses selected and the second is when nonideal effects are not modeled adequately, the latter causing an imperfect match, even if small measurement errors are allowed for. In both cases, a family of solutions for circuit model parameters may exist which produce a reasonable and similar match between measured and simulated responses [51]. Such problems become more difficult to handle with a large number of variables, where a direct optimization is hopeless unless started with accurate estimates of most circuit element values from independent measurements or calculations [49, 52].

Efforts to alleviate those difficulties have been made in several directions. Straightforward approaches include seeking additional independent measurements and/or predetermining some variables. Since both actions reduce the freedom of variables, they can be effectively applied if a further exploitation of physical properties of a given device is permitted. However, when faced with a prescribed set of possible measurements and variables, we can proceed to general approaches such as decomposition and multicircuit measuring.

## 7.3 Reduction of Model Parameters

Reduction of model parameters may be possible by full investigation of physical properties of the device to be modeled. Such an approach was demonstrated by Curtice and Camisa in a field effect transistor (FET) modeling problem. Using DC and zero-bias measurements, they reduced the number of variables from 16 to 8. The final result of the modeling was reported to be accurate and unique [52].

In laboratory experiments, a repeated trial-and-error procedure may be necessary. Reduction of model variables can be achieved by exploiting the



laboratory experience with sample devices. Insensitive variables should be removed at initial stages of an optimization process. Variables tending to reach the upper or lower bounds during the optimization can be fixed in an appropriate manner [29, 48].

#### 7.4 Decomposition Approach

Tsironis and Meierer [49], Kondoh [50] and Bandler and Zhang [10] have suggested decomposing the overall optimization problem of (47) into a sequence of suboptimizations. They illustrated successful FET modeling by properly defining and ordering subsets of parameters and responses. Insensitively related parameters and responses are separated into different subproblems. A series of suboptimizations can provide a good starting point for the overall optimization [49]. It also improves model accuracy and reduces the possibility of stopping at an undesired local minimum.

#### 7.5 Multicircuit Approach

This approach was proposed by Bandler et al. [51]. The  $l_1$ -norm objective function was used. Suppose that after taking measurements on a device at a number of frequency points, we make an easy-to-achieve physical adjustment such that one or a few components of  $\phi$  are changed in a dominant fashion and the rest remain constant or change slightly. Consider the following optimization problem:

$$\text{minimize}_{\phi^1, \phi^2} \sum_{k=1}^2 \sum_{i=1}^{m^k} |f_i^k| + \sum_{j=1}^n \beta_j |\phi_j^1 - \phi_j^2| \quad (48)$$

with superscript  $k$  identifying the original network model ( $k = 1$ ) or the model after physical adjustment ( $k = 2$ ).  $\beta_j$  represents an appropriate weighting factor and  $m^k$  is an index whose value depends on  $k$ ; that is, a different number of frequencies may be used for the original and the perturbed model.  $\phi^1$  and  $\phi^2$  are vectors containing circuit parameters of the original and perturbed networks, respectively.

By adding the second segment to the objective function, we take advantage of the knowledge that only one or a few components of  $\phi$  should change dominantly by perturbing a physical component of the device. Therefore, we penalize the objective function for any change in  $\phi$ . However, by cleverly selecting the  $l_1$  norm, we still allow for one or a few large changes in  $\phi$ .

Confidence in the validity of the equivalent circuit parameters increases if (1) an optimization using the objective function of (48) results in a reasonable match between calculated and measured responses for both circuits 1 and 2 (original and perturbed) and (2) the examination of the solution reveals changes from  $\phi^1$  to  $\phi^2$  that are consistent with the physical adjustment; that

is, only the expected components have changed significantly. We can build our confidence even more by expanding the technique to more adjustments, that is, formulating the optimization problem as

$$\text{minimize}_{\phi'} \sum_{k=1}^{n_c} \sum_{i=1}^{m^k} |f_i^k| + \sum_{k=2}^{n_c} \sum_{j=1}^n \beta_j^k |\phi_j^1 - \phi_j^k| \quad (49)$$

where  $n_c$  circuits and their corresponding sets of responses, measurements, and parameters are considered and the first circuit is the reference model before any physical adjustment.  $\phi'$  contains all  $\phi^k$ ,  $k = 1, 2, \dots, n_c$ .

## 8 TUNING USING OPTIMIZATION METHODS

Postproduction tuning is often essential in the manufacturing of electrical circuits. Tolerances on the circuit components, parasitic effects and uncertainties in the circuit model cause deviations in the manufactured circuit's performance, and violation of the design specifications may result. Therefore, postproduction tuning is included in the final stages of the production process to readjust the network performance in an effort to meet the specifications.

Computer-aided designers have approached the tuning problem in two ways, each emphasizing one distinct facet. Before production, at the time of designing a circuit, one can consider tuning as an integral part of the design process [53, 54], the objective being to relax the tolerances on the circuit components and compensate for the uncertainties in the model parameters. The integral design problem is formulated and solved using optimization such that the essential demand of production cost reduction is optimally met. The solution of the design problem provides the manufacturer with the allowed design tolerances and the tunable parameters.

In the final production stages, the manufactured circuit is usually tested to check whether or not it meets design specifications. Tuning is often needed. Here, it is required to implement necessary changes in the tunable parameters to adjust the manufactured circuit to satisfy the design requirements [55].

### 8.1 Preproduction Tuning [53, 54]

Suppose  $\varepsilon \triangleq [\varepsilon_1 \ \varepsilon_2 \ \dots \ \varepsilon_n]^T$  and  $\mathbf{t} \triangleq [t_1 \ t_2 \ \dots \ t_n]^T$  are vectors containing tolerances and maximum tuning amounts, respectively, for the parameter  $\phi \triangleq [\phi_1 \ \phi_2 \ \dots \ \phi_n]^T$ . A nonlinear programming problem integrating design centering, tolerancing, and tuning can be stated as

$$\text{minimize}_{\phi^0, \varepsilon, \mathbf{t}} U(\phi^0, \varepsilon, \mathbf{t}) \quad (50a)$$

$$\text{s.t. } \boldsymbol{\phi} = \boldsymbol{\phi}^0 + \mathbf{E}\boldsymbol{\mu} + \mathbf{T}\boldsymbol{\rho} \in \mathbf{R}_c$$

$$\text{for all } \boldsymbol{\mu}, \quad \boldsymbol{\mu} \in \mathbf{R}_\mu$$

$$\text{and some } \boldsymbol{\rho}, \quad \boldsymbol{\rho} \in \mathbf{R}_\rho \tag{50b}$$

where  $\mathbf{E}$  and  $\mathbf{T}$  are  $n \times n$  diagonal matrices containing  $\varepsilon_i, i = 1, 2, \dots, n$ , and  $t_i, i = 1, 2, \dots, n$ , respectively, and

$$\boldsymbol{\mu} \triangleq [\mu_1 \quad \mu_2 \quad \cdots \quad \mu_n]^T \tag{51}$$

$$\boldsymbol{\rho} \triangleq [\rho_1 \quad \rho_2 \quad \cdots \quad \rho_n]^T \tag{52}$$

Also,  $\mathbf{R}_c$  is a constraint region in which all responses satisfy their specifications.  $\mathbf{R}_\mu$  is a group in which  $|\mu_i| \leq 1, i = 1, 2, \dots, n$ .  $\mathbf{R}_\rho$  is defined as the region  $\{|\boldsymbol{\rho}| - 1 \leq \rho_i \leq 1, i = 1, 2, \dots, n\}$  for two-way tuning and  $\{\boldsymbol{\rho} | 0 \leq \rho_i \leq 1, i = 1, 2, \dots, n\}$  or  $\{\boldsymbol{\rho} | -1 \leq \rho_i \leq 0, i = 1, 2, \dots, n\}$  for one-way tuning. The objective function can be an increasing function of  $|t_i/\phi_i^0|$  and a decreasing function of  $|\varepsilon_i/\phi_i^0|$ , respectively.

### 8.2 Postproduction Tuning: Problem Formulation

Prior to postproduction tuning, the manufactured circuit is characterized by the actual parameter values given by

$$\boldsymbol{\phi}^a = \boldsymbol{\phi}^0 + \mathbf{E}\boldsymbol{\mu}^a \tag{53}$$

Suppose, for convenience, that the preproduction stage resulted in  $t_i > 0$  for  $i = 1, 2, \dots, n_t$  and  $t_i = 0$  for  $i = n_t + 1, \dots, n$ . Therefore, the tunable parameters are  $\phi_i, i = 1, 2, \dots, n_t$ . A set of circuit performance functions given by

$$\mathbf{F}(\boldsymbol{\phi}, \omega) = \mathbf{F}(\boldsymbol{\phi}^0 + \mathbf{E}\boldsymbol{\mu}^a + \mathbf{T}\boldsymbol{\rho}, \omega) \tag{54}$$

are usually monitored during the tuning process. The desired values for  $\mathbf{F}$ , denoted as  $\mathbf{F}^d$ , can be either an optimal response or a design specification. Define  $\mathbf{f} = \mathbf{f}(\boldsymbol{\phi})$  as an  $m$ -vector whose elements are in the form

$$w_{Ui}(\omega_j)(F_i(\boldsymbol{\phi}, \omega_j) - S_{Ui}(\omega_j)) - w_{Li}(\omega_j)(F_i(\boldsymbol{\phi}, \omega_j) - S_{Li}(\omega_j)) \tag{55}$$

where  $i \in \{1, 2, \dots, n_F\}, j \in \{1, 2, \dots, n_\omega\}$ , and  $\boldsymbol{\phi} \equiv \boldsymbol{\phi}^0 + \mathbf{E}\boldsymbol{\mu}^a + \mathbf{T}\boldsymbol{\rho}$ .  $S_{Ui}$  and  $S_{Li}$  are upper and lower specifications, respectively.  $w_{Ui}$  and  $w_{Li}$  are weighting factors and are nonnegative. If it is required to match  $F_i(\boldsymbol{\phi}, \omega)$  with its desired value  $F_i^d(\omega)$ , one can either use (55) by setting

$$S_{Ui}(\omega) = S_{Li}(\omega) = F_i^d(\omega) \tag{56}$$

or define elements of  $\mathbf{f}$  as

$$w_i(\omega_j)|F_i(\boldsymbol{\phi}, \omega_j) - F_i^d(\omega_j)| \tag{57}$$

The postproduction tuning can be formulated as the optimization problem

$$\text{minimize}_{\boldsymbol{\rho}'} U(\boldsymbol{\rho}) \quad (58a)$$

$$\text{s.t. } |\rho_j| \leq 1, \quad j = 1, 2, \dots, n_t \quad (58b)$$

where  $\boldsymbol{\rho}'$  is an  $n_t$ -vector containing the first  $n_t$  elements in  $\boldsymbol{\rho}$ . The objective function can be a least  $p$ th or a generalized least  $p$ th function of  $\mathbf{f}(\boldsymbol{\phi}^0 + \mathbf{E}\boldsymbol{\mu}^a + \mathbf{T}\boldsymbol{\rho})$ , that is, in the forms of (2) and (3), respectively.

### 8.3 Postproduction Tuning: Functional Approach

Functional tuning is a traditional approach. The tunable parameters are sequentially adjusted until the circuit specifications are met. Here, the network elements are generally assumed unknown.

Let  $\mathbf{J}$  be an  $m \times n_t$  Jacobian matrix whose  $(i, j)$ th element is defined by

$$J_{ij} \triangleq \frac{\partial f_i}{\partial \rho_j} = \frac{\partial f_i}{\partial \phi_j} t_j, \quad i = 1, 2, \dots, m, j = 1, 2, \dots, n_t \quad (59)$$

The least-squares optimization of (58), namely taking  $U = \mathbf{f}^T \mathbf{f}$ , was proposed by Antreich et al. [56] and Adams and Manaktala [57]. The solution is given by

$$\Delta \boldsymbol{\rho}' = -(\mathbf{J}^T \mathbf{J})^{-1} \mathbf{J}^T \mathbf{f}(\boldsymbol{\phi}^0 + \mathbf{E}\boldsymbol{\mu}^a + \mathbf{T}\boldsymbol{\rho}) \quad (60)$$

The minimax optimization of (58), namely taking  $U = \max f_i$ , was approximated by Bandler and Salama [43, 55, 58], who solved the following linear programming problem:

$$\text{minimize}_{\Delta \boldsymbol{\rho}', z} z \quad (61a)$$

$$\text{s.t. } f_i(\boldsymbol{\phi}^0 + \mathbf{E}\boldsymbol{\mu}^a + \mathbf{T}\boldsymbol{\rho}) + \sum_{j=1}^{n_t} J_{ij} \Delta \rho_j \leq z \quad (61b)$$

$$\rho_{Lj} \leq \Delta \rho_j \leq \rho_{Uj}, \quad i = 1, 2, \dots, m, j = 1, 2, \dots, n_t$$

$\boldsymbol{\rho}$  is initially set to  $\mathbf{0}$ . After each solution of (60) or (61),  $\boldsymbol{\rho}$  is updated using  $\Delta \boldsymbol{\rho}'$ . As proposed by Bandler and Salama, simulated sensitivities and the Broyden formula can be used for obtaining and updating  $\mathbf{J}$ .

### 8.4 Postproduction Tuning: Deterministic Approach

In contrast to the functional tuning approach, deterministic tuning requires that all circuit parameters  $\boldsymbol{\phi}$  and possible parasitic parameters  $\boldsymbol{\zeta}$  (or its effects)

can be either measured or identified. By utilizing this information, the optimization of (58) becomes faster.

A sequential tuning algorithm has been introduced by Lopresti [59]. Let  $\mathbf{f}$  be the  $m$ -vector defined in (55) or (57). Initially, we set  $\boldsymbol{\rho} = \mathbf{0}$  and define

$$\mathbf{f}_1 \triangleq \sum_{i=n_t+1}^n \phi_i \frac{\partial \mathbf{f}}{\partial \phi_i} \frac{\Delta \phi_i}{\phi_i} + \sum_i \zeta_i \frac{\partial \mathbf{f}}{\partial \zeta_i} \frac{\Delta \zeta_i}{\zeta_i} \tag{62}$$

which represents the deviation of  $\mathbf{f}$  from  $\mathbf{f}(\boldsymbol{\phi}^0)$  due to parasitic effects and tolerances in untunable parameters. In the  $k$ th iteration, we have

$$\mathbf{f}^{k+1} = \mathbf{f}^k + [J_{1k} J_{2k} \cdots J_{mk}]^T \Delta \boldsymbol{\rho}_k, \quad k = 1, 2, \dots, n_t \tag{63}$$

By defining  $U$  of (58) as a quadratic function of  $\mathbf{f}^{n_t+1}$  and adding a term penalizing large changes in  $\Delta \boldsymbol{\rho}'$ , we obtain an optimal control problem, that is, finding  $\Delta \boldsymbol{\rho}'$  such that

$$U = (\mathbf{f}^{n_t+1})^T \mathbf{B} \mathbf{f}^{n_t+1} + \sum_{j=1}^{n_t} \beta_j (\Delta \rho_j)^2 \tag{64}$$

is minimized subject to (63).  $\mathbf{B}$  of (64) is a positive semidefinite matrix and  $\beta_j > 0, j = 1, 2, \dots, n_t$ . A closed-form solution can be obtained in the form

$$\Delta \rho_k = \boldsymbol{\gamma}_k^T \mathbf{f}^k \tag{65}$$

where  $\boldsymbol{\gamma}_k$  is an  $m$ -vector calculated using the Riccati equation [59].

Instead of using first-order sensitivity information  $\mathbf{J}$ , which becomes invalid when components of  $\Delta \boldsymbol{\rho}'$  are not small enough, Alajajian et al. suggested a large-change sensitivity method for deterministic tuning [60–62]. The resulting equation is

$$[\mathbf{J}^L \quad -\mathbf{f}(\boldsymbol{\phi}^0)] \begin{bmatrix} \Delta \boldsymbol{\rho}' \\ c \end{bmatrix} = -\mathbf{f}(\boldsymbol{\phi}^0) \tag{66}$$

where  $\mathbf{J}^L$  is the large-change sensitivity matrix of  $\mathbf{f}$  with respect to  $\boldsymbol{\rho}'$  and  $c$  is an unknown variable.

## 9 EXAMPLES

In this section, we first present the application of optimization techniques for circuit diagnosis through a simple illustrative example. This is followed by selected problems of practical interest for diagnosis, modeling, and tuning.

### 9.1 Diagnosis Using Optimization: An Illustrative Example

Consider the passive resistive network of Figure 14.2. Nominal values for elements  $G_i, i = 1, 2, \dots, 5$ , are equal to 1. Each element has  $\pm 5\%$  tolerance.

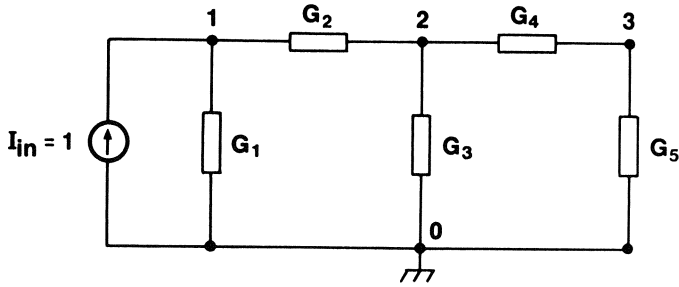

**Figure 14.2** Passive resistive circuit as an example for diagnosis using optimization techniques.

The measurable responses are nodal voltages,  $\mathbf{F} = [V_1 \ V_2 \ V_3]^T$ , causing the  $\mathbf{C}$  of (11) to be a  $3 \times 3$  identity matrix. Also for the example,  $N = 3$ ,  $n_F = 3$ , and  $n = 5$ . The incidence matrix is given by

$$\mathbf{Q} = \begin{bmatrix} 1 & 1 & 0 & 0 & 0 \\ 0 & -1 & 1 & 1 & 0 \\ 0 & 0 & 0 & -1 & 1 \end{bmatrix} \quad (67)$$

The variable parameters are defined as  $\boldsymbol{\phi} = [G_1 \ G_2 \ G_3 \ G_4 \ G_5]^T$ . The nodal admittance matrix at nominal point  $\boldsymbol{\phi}^0 = [1 \ 1 \ 1 \ 1 \ 1]^T$  is

$$\mathbf{Y}(\boldsymbol{\phi}^0) = \begin{bmatrix} 2 & -1 & 0 \\ -1 & 3 & -1 \\ 0 & -1 & 2 \end{bmatrix} \quad (68)$$

For such a circuit, all quantities are real. Therefore, the constraint equations as well as the related definitions (17)–(20) become

$$\mathbf{Ax} = \mathbf{b} \quad (69)$$

where

$$\begin{aligned} \mathbf{A} &= -\mathbf{C}^T[\mathbf{Y}(\boldsymbol{\phi}^0)]^{-1}\mathbf{Q} \\ &= \frac{-1}{8} \begin{bmatrix} 5 & 3 & 2 & 1 & 1 \\ 2 & -2 & 4 & 2 & 2 \\ 1 & -1 & 2 & -3 & 5 \end{bmatrix} \end{aligned} \quad (70)$$

$$\mathbf{b} = \mathbf{F}^M - \mathbf{F}^0 = [V_1^M - V_1^0 \ V_2^M - V_2^0 \ V_3^M - V_3^0]^T \quad (71)$$

and

$$\mathbf{x} = [\Delta I_1^b \ \Delta I_2^b \ \Delta I_3^b \ \Delta I_4^b \ \Delta I_5^b]^T \quad (72)$$

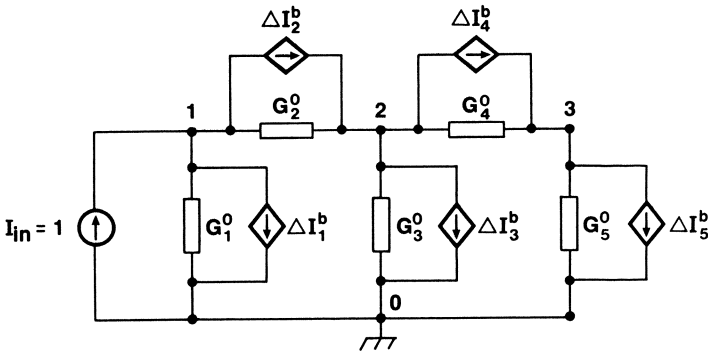

**Figure 14.3** Equivalent current sources representing the effect of changes in  $G_i, i = 1, 2, \dots, 5$ , for the circuit of Figure 14.2.  $\Delta I_i^b = \Delta G_i V_i^b$ , where  $V_i^b$  is the voltage across the  $i$ th element.

where  $\Delta I_i^b, i = 1, 2, \dots, 5$  are the equivalent current sources representing  $\Delta G_i, i = 1, 2, \dots, 5$ , shown in Figure 14.3. The nominal responses  $\mathbf{F}^0 = [V_1^0 \ V_2^0 \ V_3^0]^T$  can be calculated as  $\mathbf{F}^0 = [5/8 \ 2/8 \ 1/8]^T$ .

*Case 1:* We assume that no elements have much greater deviation from nominal than others. Table 14.1 shows the results of diagnosis using the  $l_1$  and  $l_2$  techniques and the quadratic programming method. It is demonstrated that the least-squares method gives a more reasonable solution, while the other two methods have mistakenly detected, e.g.,  $G_4$  as nonfaulty while this element actually changed 30% for CUT # 1. However, the  $l_2$  optimization method may also fail to give correct results; see CUT # 3, where the  $G_2$  and the  $G_5$  are not detected as out of tolerance.

*Case 2:* We assume that only a few elements are faulty and that they have much greater deviation from nominal than the rest of the elements, which are within the specified tolerance of  $\pm 5\%$ . Table 14.2 shows the results of diagnosis using the three optimization techniques presented. It can be seen that both the  $l_1$  and quadratic techniques give much sharper results than the  $l_2$  technique. In many cases, both  $l_1$  and the quadratic optimization produce the same solution. In some cases, as shown for CUT # 2 and CUT # 3 in Table 14.2, one method yields a better solution than the other.

For the quadratic programming technique, we used  $\delta = 10^{-6}$  and  $\beta = 10^{10}$ . The QPSOL FORTRAN package for quadratic programming [28] was utilized to perform step 3 in Section 5 with a limit on the number of iterations for each quadratic programming as 3.

**Table 14.1** Results of Diagnosis Using Optimization Techniques for the Circuit of Figure 14.2, Case 1

| CUT | Measurement<br>$V^M$ | Actual<br>$\Delta G_i/G_i^{\circ\%}$<br>$i = 1, 2, \dots, 5$ | Detected $\Delta G_i/G_i^{\circ\%}$ , $i = 1, 2, \dots, 5$ |                          |                       |
|-----|----------------------|--|--|--------------------------|-----------------------|
|     |                      |  | $l_2$<br>optimization                                      | Quadratic<br>programming | $l_1$<br>optimization |
| #1  | 0.5730               | 4.4  | 4.36   | 14.02                    | 13.23                 |
|     | 0.2326               | 18.0   | 18.07  | 1.80                     | 3.14                  |
|     | 0.1186               | 9.0  | 7.61   | 0.00                     | 0.00                  |
| #2  |                      | 30.0   | 33.04  | 0.00                     | 4.00                  |
|     |                      | 25.0   | 27.93  | -3.85                    | 0.00                  |
|     | 0.6437               | -2.0   | -2.38  | 0.00                     | 0.00                  |
|     | 0.2241               | -12.0  | -11.41   | -15.07                   | -15.07                |
|     | 0.1145               | 6.0  | 5.28   | 7.92                     | 7.92                  |
| #3  |                      | 20.0   | 23.73  | 4.35                     | 4.35                  |
|     |                      | 15.0   | 18.58  | 0.00                     | 0.00                  |
|     | 0.6266               | 3.0  | -0.42  | 0.00                     | 0.00                  |
|     | 0.2412               | -8.0   | -2.44  | -3.12                    | -3.12                 |
|     | 0.1307               | -3.4   | 1.96   | 0.60                     | 0.60                  |
|     |                      | 10.0   | 17.69  | 18.28                    | 18.28                 |
|     |                      | -7.0   | -0.50  | 0.00                     | 0.00                  |



**Table 14.2** Results of Diagnosis Using Optimization Techniques for the Circuit of Figure 14.2, Case 2

| CUT | Measurement<br>$V^M$ | Actual<br>$\Delta G_i/G_i\%$<br>$i = 1, 2, \dots, 5$ | Detected $\Delta G_i/G_i^{0\%}, i = 1, 2, \dots, 5$ |                          |                       |
|-----|----------------------|--|---|--------------------------|-----------------------|
|     |                      |  | $l_2$<br>optimization                               | Quadratic<br>programming | $l_1$<br>optimization |
| #1  | 0.5000               | 0.0  | 16.98   | 0.00                     | 0.00                  |
|     | 0.3333               | 200.0  | 149.06  | 200.00                   | 200.00                |
|     | 0.1667               | 0.0  | -8.49   | 0.00                     | 0.00                  |
| #2  |                      | 0.0  | -33.96  | 0.00                     | 0.00                  |
|     |                      | 0.0  | -33.96  | 0.00                     | 0.00                  |
|     | 0.5933               | 2.0  | 1.95  | 1.77                     | 5.77                  |
|     | 0.2207               | 6.0  | 6.08  | 6.36                     | 0.00                  |
|     | 0.1755               | -3.0   | 9.68  | 0.00                     | 0.00                  |
| #3  |                      | 300.0  | 238.72  | 288.35                   | 235.89                |
|     |                      | 3.0  | -12.78  | 0.00                     | -13.51                |
|     | 0.2688               | 200.0  | 63.71   | 199.62                   | 199.04                |
|     | 0.1304               | 40.0   | 304.67  | 40.73                    | 41.87                 |
|     | 0.0660               | -3.0   | 93.19   | 0.00                     | 0.00                  |
|     | 4.5                  | 378.57   | 0.00  | 2.45                     |                       |
|     | 2.0                  | 367.12   | -2.39   | 0.00                     |                       |

### 9.2 Diagnosis of a 28-Node Circuit

Kellermann [63] experimented with the nonlinear optimization problem of (9) with  $p = 1$ , on a 28-node circuit shown in Figure 14.4. The nominal values of the elements  $G_i = 1.0$  and tolerances  $\varepsilon_i = \pm 0.05$ ,  $i = 1, 2, \dots, 52$ . All outside nodes are assumed to be accessible for measurements. The actual circuit includes four faults where elements  $G_{41}$ ,  $G_{44}$ ,  $G_{45}$ , and  $G_{48}$  have  $-50\%$  deviation from nominal. All other element values are within their tolerances. The diagnosis was performed successfully with only one excitation. Resulting deviations for  $G_{41}$ ,  $G_{44}$ ,  $G_{45}$ , and  $G_{48}$  are  $-46$ ,  $-54$ ,  $-45$ , and  $-53\%$ ,

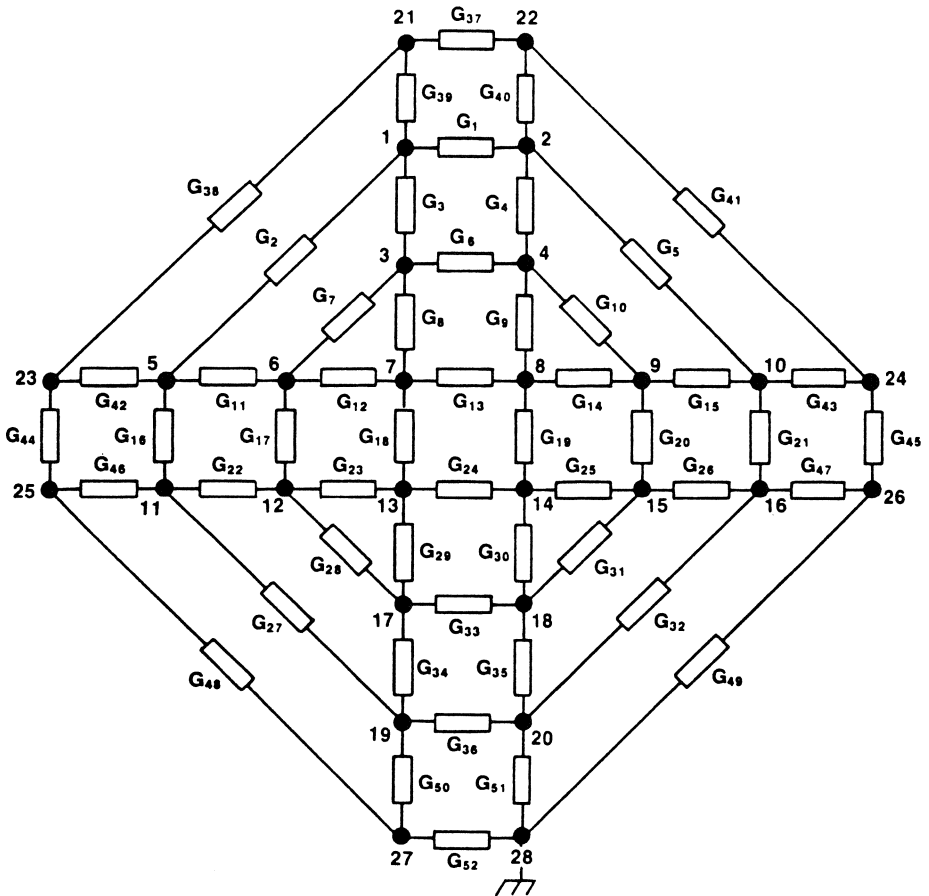
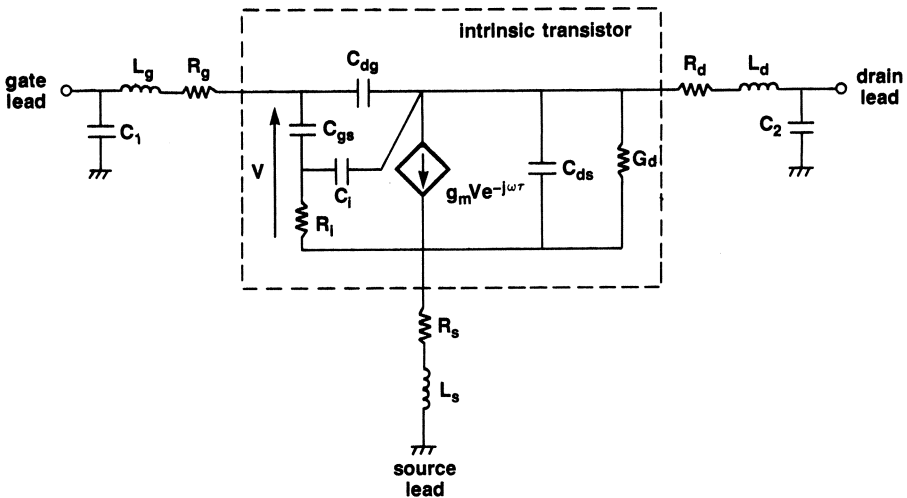

Figure 14.4 Resistive mesh network (28 nodes).

respectively. Deviations for other elements are mostly zero except for a few small nonzero values.

### 9.3 GaAs FET Modeling: Multicircuit Approach

This example is due to Bandler et al. [51]. They used the equivalent circuit at normal operating bias (including the carrier), as illustrated in Figure 14.5, and created artificial measurements using TOUCHSTONE [64]. Two sets of  $S$ -parameter (scattering) measurements were created, one set using the parameters reported by Curtice and Camisa [52] (operating bias  $V_{ds} = 8.0$  V,  $V_{gs} = -2.0$  V, and  $I_{ds} = 128.0$  mA) and the other by changing the values of  $C_1$ ,  $C_2$ ,  $L_g$ , and  $L_d$  to simulate the effect of taking different reference planes for the carriers. Both sets of data are shown in Figure 14.6, where the  $S$ -parameters of the two circuits are plotted on a Smith chart. Although the maximum number of possible variables, namely 32 (16 for each circuit), were allowed for in the optimization, the intrinsic parameters were found to be the same between the two circuits, and, as expected,  $C_1$ ,  $C_2$ ,  $L_g$ , and  $L_d$  changed from circuit 1 to 2. Table 14.3 summarizes the parameter values obtained. The problem involved 128 nonlinear functions (real and imaginary parts of four  $S$ -parameters, at eight frequencies, for two circuits), 16 linear functions, and 32 variables.



**Figure 14.5** Equivalent circuit of carrier-mounted FET (device model B1824-20C).

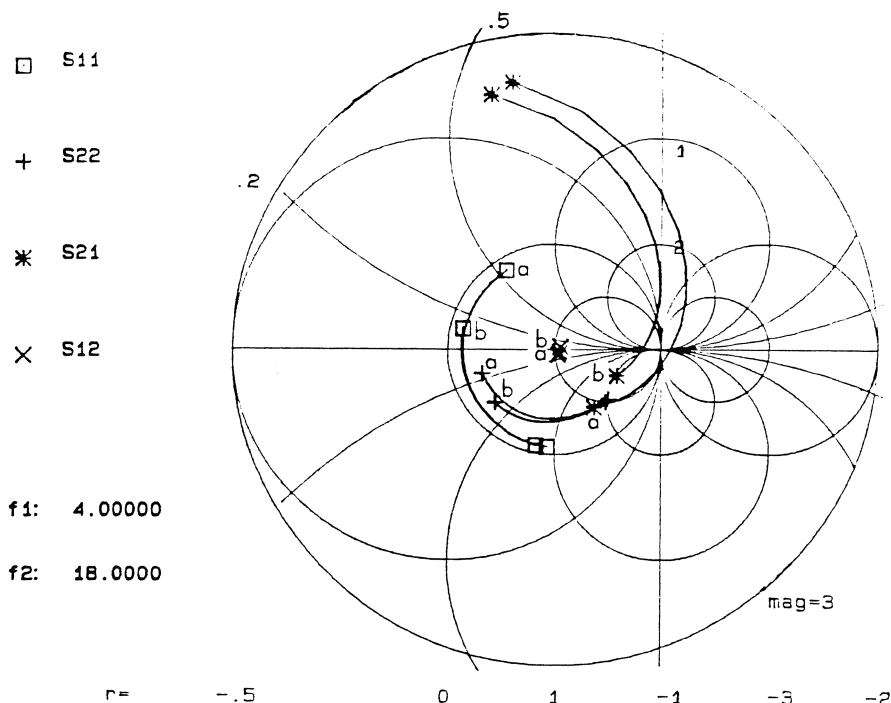

**Figure 14.6** Smith chart display of scattering parameters  $S_{11}$ ,  $S_{22}$ ,  $S_{12}$ , and  $S_{21}$  for the carrier-mounted FET, before and after adjustments on parameters. Points a and b mark the high-frequency end of the original and perturbed network responses, respectively.

#### 9.4 A High-Pass Filter Example for Postproduction Tuning

The high-pass notch filter circuit shown in Figure 14.7 was used by Bandler and Salama to demonstrate postproduction tuning algorithms [55]. The circuit example was originally employed by Alajajian [60].  $R_3$ ,  $R_5$ ,  $R_6$ , and  $R_7$  are tunable parameters. The nominal and actual element values are given in Table 14.4.

To use the functional tuning approach of (61), Bandler and Salama defined  $f_i$  as the absolute value of  $V_{out}$  from its nominal, that is, using (57) with  $F(\Phi, \omega) = V_{out}(\Phi, \omega)$  and  $F^d(\omega) = V_{out}(\Phi^0, \omega)$ . Twenty frequencies on the interval 410–505 Hz were used. The limits in (61b) are  $\rho_{Uj} = -\rho_{Lj} = 0.02$ . After 11 iterations, the tuned responses very closely approached the nominal responses, as shown in Figure 14.8a. After tuning, the values for tunable parameters  $[R_3 \ R_5 \ R_6 \ R_7] = [201.952 \ 2.115 \ 13.061 \ 0.973]$ .

**Table 14.3** Results for the GaAs FET Example

| Parameter                | Original circuit | Perturbed circuit   |
|--------------------------|------------------|---------------------|
| $C_1$ (pF)               | 0.0440           | 0.0200 <sup>a</sup> |
| $C_2$ (pF)               | 0.0389           | 0.0200 <sup>a</sup> |
| $C_{dg}$ (pF)            | 0.0416           | 0.0416              |
| $C_{gs}$ (pF)            | 0.6869           | 0.6869              |
| $C_{ds}$ (pF)            | 0.1900           | 0.1900              |
| $C_i$ (pF)               | 0.0100           | 0.0100              |
| $R_g$ ( $\Omega$ )       | 0.5490           | 0.5490              |
| $R_d$ ( $\Omega$ )       | 1.3670           | 1.3670              |
| $R_s$ ( $\Omega$ )       | 1.0480           | 1.0480              |
| $R_i$ ( $\Omega$ )       | 1.0842           | 1.0842              |
| $G_d^{-1}$ (k $\Omega$ ) | 0.3761           | 0.3763              |
| $L_g$ (nH)               | 0.3158           | 0.1500 <sup>a</sup> |
| $L_d$ (nH)               | 0.2515           | 0.1499 <sup>a</sup> |
| $L_s$ (nH)               | 0.0105           | 0.0105              |
| $g_m$ (S)                | 0.0423           | 0.0423              |
| $\tau$ (ps)              | 7.4035           | 7.4035              |

<sup>a</sup>Significant change in parameter value.

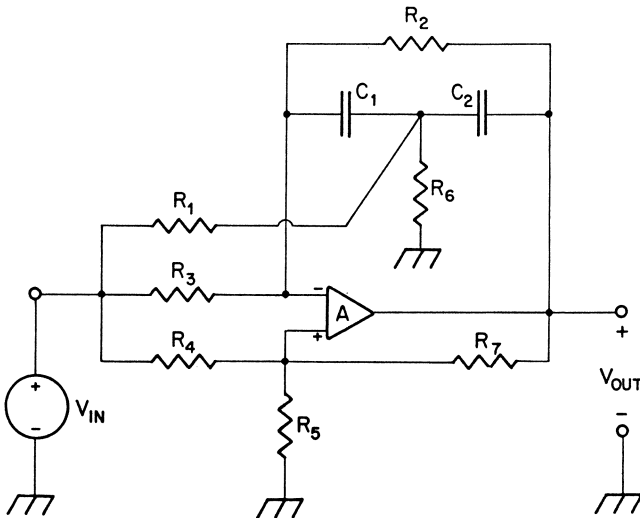

**Figure 14.7** The high-pass notch filter circuit.

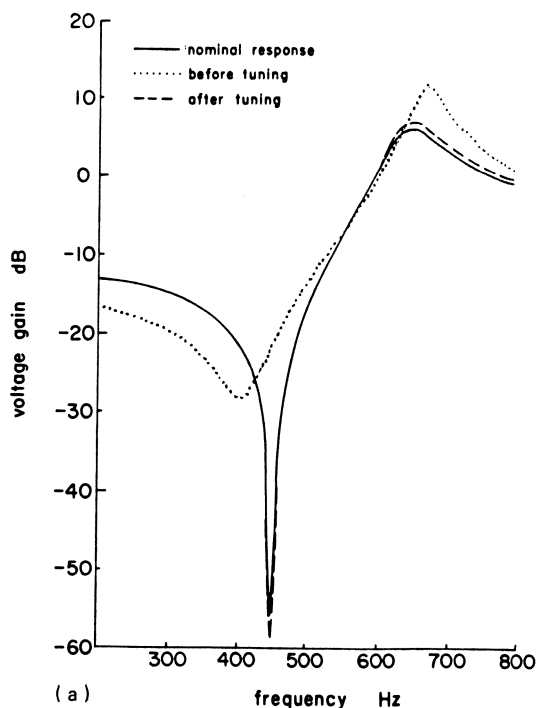

**Figure 14.8** Responses for tuning of the high-pass notch filter. (a) Functional tuning. (b) Deterministic tuning.

**Table 14.4** Element Values for the High-Pass Filter of Figure 14.7

| Element             | Nominal value | Actual value | Percentage deviation |
|---------------------|---------------|--------------|----------------------|
| $R_1$ (k $\Omega$ ) | 13.260        | 13.260       | 0.0                  |
| $R_2$ (k $\Omega$ ) | 93.0          | 93.0         | 0.0                  |
| $R_3$ (k $\Omega$ ) | 214.0         | 192.6        | -10.0                |
| $R_4$ (k $\Omega$ ) | 2.0           | 2.0          | 0.0                  |
| $R_5$ (k $\Omega$ ) | 2.0           | 1.8          | -10.0                |
| $R_6$ (k $\Omega$ ) | 12.467        | 11.221       | -10.0                |
| $R_7$ (k $\Omega$ ) | 10.00         | 9.00         | -10.0                |
| $C_1$ ( $\mu$ F)    | 0.01          | 0.00973      | -2.07                |
| $C_2$ ( $\mu$ F)    | 0.01          | 0.00965      | -3.35                |
| $A$                 | 10,000.0      | 10,000.0     | 0.0                  |

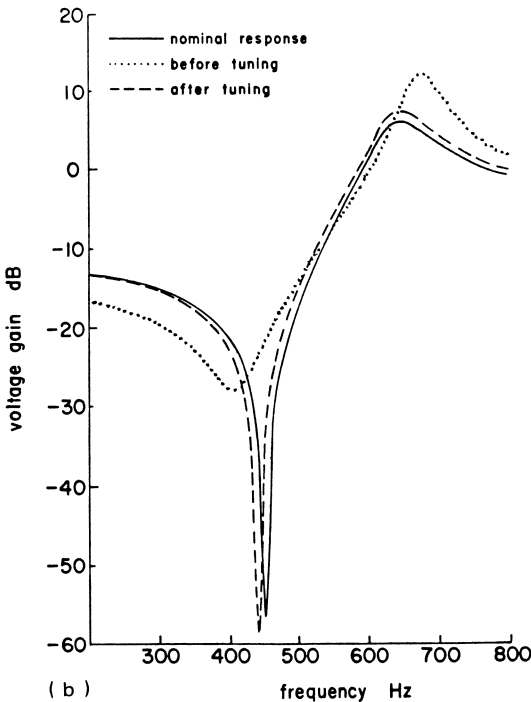

The deterministic approach of (62)–(65) was performed with  $\mathbf{F} = [F_1 \ F_2 \ \cdots \ F_5]^T$ , where the  $F_i$  are coefficients in the transfer function of the filter  $\Gamma = (s^2 + F_1s + F_2)^{-1}(F_3s^2 + F_4s + F_5)$ .  $\mathbf{B}$  of (64) was taken as  $\text{diag}\{4, 0.04, 4, 10^{12}, 0.0625\}$  and  $\beta_j = 0.001$ . The response associated with the tuning is shown in Figure 14.8b. After tuning, the values for tunable parameters  $[R_3 \ R_5 \ R_6 \ R_7]$  are  $[184.487 \ 2.241 \ 13.747 \ 0.9993]$ .

## 10 DISCUSSION

Close links and similarities exist between optimization techniques for modeling, diagnosis, and tuning. In this section, relevant common aspects are discussed.

### 10.1 Sensitivity Matrix

Suppose  $\mathbf{f}(\boldsymbol{\phi})$  is defined by (46) for modeling and diagnosis and by (55) or (57) for design and tuning. Let  $\boldsymbol{\phi}^0$  be the design nominal. Define the  $n \times m$

sensitivity matrix as

$$\mathbf{S}(\boldsymbol{\phi}) \triangleq \text{diag}\{\boldsymbol{\phi}^0\} \frac{\partial \mathbf{f}^T(\boldsymbol{\phi})}{\partial \boldsymbol{\phi}} \text{diag}\{\mathbf{f}(\boldsymbol{\phi}^0)\}^{-1} \quad (73)$$

$\boldsymbol{\phi}^*$  is said to be a regular point [65] of  $\mathbf{S}(\boldsymbol{\phi})$  if there exists an open neighborhood of  $\boldsymbol{\phi}^*$  in which  $\mathbf{S}(\boldsymbol{\phi})$  has constant rank. Parameter identification (or modeling) is usually performed with the assumption that the actual parameter  $\boldsymbol{\phi}^a$  is at a regular point and  $\text{Rank}[\mathbf{S}(\boldsymbol{\phi}^a)] = n$ . Otherwise, if  $\text{Rank}[\mathbf{S}(\boldsymbol{\phi}^a)] < n$ , that is, the measurement is not sufficient, we should either use the diagnosis technique introduced in Sections 3 to 6 or seek possible additional measurements by creating any or a combination of (1) more accessible nodes for excitation and/or measurement, (2) more frequency points, (3) other types of responses (e.g., voltage and current), and (4) additional circuits obtained by perturbing a few parameters in the CUT. Research has been performed on the selection of excitation and measurement ports and frequencies [42] as well as the multitype response and multicircuit concepts, e.g., [51].

In tuning problems, it is desired that the submatrix containing the first  $n_i$  rows of  $\mathbf{S}$  (assuming that only the first  $n_i$  elements in  $[\phi_1 \ \phi_2 \ \cdots \ \phi_n]^T$  are tunable) has a rank which should be as high as the rank of  $\mathbf{S}$ . Such rank comparison implicates the degree of difficulty to achieve the desired response by tuning  $\phi_i$ ,  $i = 1, 2, \dots, n_i$ , only.

By checking the  $\mathbf{S}$  matrix, possible decomposition can be carried out, sequentially optimizing subsets of responses versus variables that are sensitively related [10].

## 10.2 Large-Change Sensitivity

The embedding of large-change sensitivity calculations in an optimization procedure, where only a small subset of circuit parameters are updated each iteration, can greatly increase the efficiency. The application of Householder's formula in fault diagnosis was reported [66–68]. Such application can reduce reevaluation of  $\mathbf{F}(\boldsymbol{\phi})$  from the order of  $n$  to  $r$ ,  $r$  being a rank measure of the subcircuit to be updated.  $r$  is less than or equal to the number of parameters in the subcircuit [33, 69].

## 10.3 Convergence

For problems using the  $l_1$  and minimax optimization method of Hald and Madsen [17, 18, 23–26], superlinear or quadratic convergence is guaranteed. The convergence for Merrill's quadratic approach was reported to be about two or three iterations. For a decomposed problem, sequential optimization may diverge if the subproblems are not well defined or not reasonably



ordered. Therefore, it may be desirable to have the system less decomposed as the solution is being approached. Usually, an optimization converges only to a local minimum unless the objective and the constraints satisfy certain conditions. Global optimization methods are being studied [70].

#### 10.4 Possible Difficulties and Disadvantages

Poor or unacceptable results in computer-aided circuit optimization are felt to be most likely due to bad preparation of the problem, lack of understanding of the hazards that can be encountered, and the wrong choice of algorithm [5]. Compared with other techniques for modeling, diagnosis, and tuning (if applicable), optimization techniques often require more computer time and storage. The choice of starting point is often a demanding task for satisfactory solution and fast convergence.

### 11 CONCLUSION

We have presented basic principles of optimization techniques for modeling, diagnosis, and tuning. Emphasis is centered on the problem formulation and related properties rather than mathematical sophistication of optimization procedures and detailed circuit aspects of MDT. Further research can be directed toward effective modeling techniques to improve the validity of identified parameters. The use and organization of decomposition need further investigation. The desired outcome is an automatic procedure capable of identifying circuit parameters and making decisions concerning physical adjustments based on monitored response and identified parameters.

### ACKNOWLEDGEMENTS

The authors thank Dr. T. Ozawa, editor of this book, for his invitation of this contribution. The authors benefited from the work of Dr. A. E. Salama of Cairo University, Giza, Egypt. Fruitful interactions, particularly on the modeling problem, with Dr. S. Daijavad, now at IBM T. J. Watson Research Center, Yorktown Heights, N.Y., and Dr. S. H. Chen, now with Optimization Systems Associates Inc., Dundas, Ontario, Canada, are gratefully appreciated.

### REFERENCES

1. G. C. Temes and D. A. Calahan, Computer-aided network optimization: The state-of-the-art, *Proc. IEEE*, vol. 55, pp. 1832–1863, 1967.
2. G. C. Temes, Optimization methods in circuit design, in *Computer Oriented Circuit Design*, F. F. Kuo and W. G. Magnuson, Jr., eds., Prentice-Hall, Englewood Cliffs, N.J., 1969.

3. A. D. Waren, L. S. Lasdon, and D. F. Suchman, Optimization in engineering design, *Proc. IEEE*, vol. 55, pp. 1885–1897, 1967.
4. J. W. Bandler, Optimization methods for computer-aided design, *IEEE Trans. Microwave Theory Tech.*, vol. MTT-17, pp. 533–552, 1969.
5. J. W. Bandler, Computer-aided circuit optimization, in *Modern Filter Theory and Design*, G. C. Temes and S. K. Mitra, eds., Interscience, New York, 1973.
6. J. W. Bandler and M. R. M. Rizk, Optimization of electrical circuits, *Mathematical Programming Study on Engineering Optimization*, vol. 11, pp. 1–64, 1979.
7. S. W. Director, Survey of circuit oriented optimization techniques, *IEEE Trans. Circuit Theory*, vol. CT-18, pp. 3–10, 1971.
8. C. Charalambous, A unified review of optimization, *IEEE Trans. Microwave Theory Tech.*, vol. MTT-22, pp. 289–300, 1974.
9. R. K. Brayton, G. D. Hachtel, and A. L. Sangiovanni-Vincentelli, A survey of optimization techniques for integrated-circuit design, *Proc. IEEE*, vol. 69, pp. 1334–1362, 1981.
10. J. W. Bandler and Q. J. Zhang, An automatic decomposition approach to optimization of large microwave systems, *IEEE Trans. Microwave Theory Tech.*, vol. MTT-35, December 1987.
11. D. G. Luenberger, *Linear and Nonlinear Programming*, 2nd ed., Addison-Wesley, Reading, Mass., 1984.
12. A. Emmett, Karmarkar's algorithm: A threat to simplex?, *IEEE Spectrum*, vol. 22, no. 12, pp. 54–55, Dec. 1985.
13. N. Karmarkar, A new polynomial-time algorithm for linear programming, *Combinatorica*, vol. 4, pp. 373–395, 1984.
14. G. C. Temes and D. Y. F. Zai, Least  $p$ th approximation, *IEEE Trans. Circuit Theory*, vol. CT-16, pp. 235–237, 1969.
15. J. W. Bandler and C. Charalambous, Theory of generalized least  $p$ th approximation, *IEEE Trans. Circuit Theory*, vol. CT-19, pp. 287–289, 1972.
16. J. W. Bandler and C. Charalambous, Practical least  $p$ th optimization of networks, *IEEE Trans. Microwave Theory Tech.*, vol. MTT-20, pp. 834–840, 1972.
17. J. Hald and K. Madsen, Combined LP and quasi-Newton methods for nonlinear  $l_1$  optimization, *SIAM J. Numer. Anal.*, vol. 22, pp. 68–80, 1985.
18. J. Hald, A 2-stage algorithm for nonlinear  $l_1$  optimization, Institute for Numerical Analysis, Technical University of Denmark, Lyngby, Rep. No. NI-81-03, 1981.
19. J. E. Dennis, Jr., Non-linear least squares and equations, in *The State of the Art in Numerical Analysis*, D. Jacobs, ed., Academic Press, New York, 1977.

20. D. W. Marquardt, An algorithm for least-squares estimation of non-linear parameters, *SIAM J. Appl. Math.*, vol. 11, pp. 431–441, 1963.
21. M. Z. Nashed, ed., *Generalized Inverses and Applications*, Academic Press, New York, 1976.
22. C. R. Rao and S. K. Mitra, *Generalized Inverse of Matrices and Its Applications*, Wiley, New York, 1971.
23. J. Hald and K. Madsen, Combined LP and quasi-Newton methods for minimax optimization, *Math. Program.*, vol. 20, pp. 49–62, 1981.
24. J. W. Bandler and W. M. Zuberek, MMLC—a Fortran package for linearly constrained minimax optimization, Department of Electrical and Computer Engineering, McMaster Univ., Hamilton, Canada, Rep. SOS-82-5-U2, 1983.
25. J. W. Bandler, W. Kellermann and K. Madsen, A nonlinear  $l_1$  optimization algorithm for design, modelling and diagnosis of networks, *IEEE Trans. Circuits Syst.*, vol. CAS-34, pp. 174–181, 1987.
26. J. W. Bandler, W. Kellermann, and K. Madsen, A superlinearly convergent minimax algorithm for microwave circuit design, *IEEE Trans. Microwave Theory Tech.*, vol. MTT-33, pp. 1519–1530, 1985.
27. P. E. Gill and W. Murray, Linearly-constrained problems including linear and quadratic programming, in *The State of the Art in Numerical Analysis*, D. Jacobs, ed., Academic Press, New York, 1977.
28. P. E. Gill, W. Murray, M. A. Saunders, and M. H. Wright, User's guide for QPSOL: A Fortran package for quadratic programming, Systems Optimization Laboratory, Department of Operations Research, Stanford Univ., Stanford, Calif., Tech. Rep. SOL 84-6, 1984.
29. G. D. Hachtel, T. R. Scott, and R. P. Zug, An interactive linear programming approach to model parameter fitting and worst-case circuit design, *IEEE Trans. Circuits Syst.*, vol. CAS-27, pp. 871–881, 1980.
30. S. W. Director and R. A. Rohrer, The generalized adjoint network and network sensitivities, *IEEE Trans. Circuit Theory*, vol. CT-16, pp. 318–323, 1969.
31. S. W. Director and R. A. Rohrer, Automated network design—the frequency domain case, *IEEE Trans. Circuit Theory*, vol. CT-16, pp. 330–337, 1969.
32. F. H. Branin, Jr., Network sensitivity and noise analysis simplified, *IEEE Trans. Circuit Theory*, vol. CT-20, pp. 285–288, 1973.
33. J. W. Bandler and Q. J. Zhang, Large change sensitivity analysis in linear systems using generalized Householder formulas, *Int. J. Circuit Theory Appl.*, vol. 14, pp. 89–101, 1986.
34. J. W. Bandler, S. Daijavad, and Q. J. Zhang, Computer aided design of branched cascaded networks, *Proc. IEEE Int. Symp. Circuits Syst.*, Kyoto, Japan, pp. 1579–1582, 1985.

35. C. G. Broyden, A class of methods for solving nonlinear simultaneous equations, *Math. Comput.*, vol. 19, pp. 577–593, 1965.
36. J. W. Bandler, S. H. Chen, S. Daijavad and K. Madsen, Efficient optimization with integrated gradient approximations, *IEEE Trans. Microwave Theory Tech.*, vol. MTT-36, February 1988.
37. R. DeCarlo and R. Saeks, *Interconnected Dynamical Systems*, Marcel Dekker, New York, 1981.
38. M. N. Ransom and R. Saeks, The connection function—theory and application, *Int. J. Circuit Theory Appl.*, vol. 3, pp. 5–21, 1975.
39. M. N. Ransom and R. Saeks, Fault isolation with insufficient measurements, *IEEE Trans. Circuit Theory*, vol. CT-20, pp. 416–417, 1973.
40. J. W. Bandler, R. M. Biernacki, and A. E. Salama, A linear programming approach to fault location in analog circuits, *Proc. IEEE Int. Symp. Circuits Syst.*, Chicago, pp. 256–260, 1981.
41. J. W. Bandler, R. M. Biernacki, A. E. Salama, and J. A. Starzyk, Fault isolation in linear analog circuits using the  $l_1$  norm, *Proc. IEEE Int. Symp. Circuits Syst.*, Rome, pp. 1140–1143, 1982.
42. J. W. Bandler and A. E. Salama, Fault diagnosis of analog circuits, *Proc. IEEE*, vol. 73, pp. 1279–1325, 1985.
43. A. E. Salama, Fault analysis and parameter tuning in analog circuits, Ph.D. Thesis, McMaster Univ., Hamilton, Canada, 1983.
44. J. W. Bandler and A. E. Salama, Recent advances in fault location of analog networks, *Proc. IEEE Int. Symp. Circuits Syst.*, Montreal, pp. 660–663, 1984.
45. K. H. Leung and R. Spence, Multiparameter large change sensitivity analysis and systematic exploration, *IEEE Trans. Circuits Syst.*, vol. CAS-22, pp. 796–804, 1975.
46. H. M. Merrill, Failure diagnosis using quadratic programming, *IEEE Trans. Reliability*, vol. R-22, pp. 207–213, 1973.
47. I. Barrodale and F. D. K. Roberts, An efficient algorithm for discrete  $l_1$  linear approximation with linear constraints, *SIAM J. Numer. Anal.*, vol. 15, pp. 603–611, 1978.
48. R. K. Brayton and R. Spence, *Sensitivity and Optimization*, Elsevier, Amsterdam, 1980.
49. C. Tsironis and R. Meierer, Microwave wide-band model of GaAs dual gate MESFET's, *IEEE Trans. Microwave Theory Tech.*, vol. MTT-30, pp. 243–251, 1982.
50. H. Kondoh, An accurate FET modelling from measured S-parameters, *IEEE Int. Microwave Symp. Dig.* (Baltimore, Md.), pp. 377–380, 1986.
51. J. W. Bandler, S. H. Chen and S. Daijavad, Microwave device modelling using efficient  $l_1$  optimization: a novel approach, *IEEE Trans. Microwave Theory Tech.*, vol. MTT-34, pp. 1282–1293, 1986.

52. W. R. Curtice and R. L. Camisa, Self-consistent GaAs FET models for amplifier design and device diagnostics, *IEEE Trans. Microwave Theory Tech.*, vol. MTT-32, pp. 1573–1578, 1984.
53. J. W. Bandler, P. C. Liu, and H. Tromp, A nonlinear programming approach to optimal design centering, tolerancing and tuning, *IEEE Trans. Circuits Syst.*, vol. CAS-23, pp. 155–165, 1976.
54. E. Polak and A. Sangiovanni-Vincentelli, Theoretical and computational aspects of the optimal design centering, tolerancing and tuning problem, *IEEE Trans. Circuits Syst.*, vol. CAS-26, pp. 795–813, 1979.
55. J. W. Bandler and A. E. Salama, Postproduction tuning employing network sensitivities, *Proc. European Conf. Circuit Theory and Design*, The Hague, Netherlands, pp. 704–709, 1981.
56. K. Antreich, E. Gleissner, and G. Müller, Computer aided tuning of electrical circuits, *Nachrichtentech. Z.*, vol. 28, no. 6, pp. 200–206, 1975.
57. R. L. Adams and V. K. Manaktala, An optimization algorithm suitable for computer-assisted network tuning, *Proc. IEEE Int. Symp. Circuits Syst.*, Newton, Mass., pp. 210–212, 1975.
58. J. W. Bandler and A. E. Salama, Functional approach to microwave postproduction tuning, *IEEE Trans. Microwave Theory Tech.*, vol. MTT-33, pp. 302–310, 1985.
59. P. V. Lopresti, Optimum design of linear tuning algorithms, *IEEE Trans. Circuits Syst.*, vol. CAS-24, pp. 144–151, 1977.
60. C. J. Alajajian, A new algorithm for the tuning of analog filters, Ph.D. Thesis, Univ. of Illinois, Urbana-Champaign, 1979.
61. C. J. Alajajian, T. N. Trick, and E. I. El-Masry, On the design of an efficient tuning algorithm, *Proc. IEEE Int. Symp. Circuits Syst.*, Houston, Texas, pp. 807–811, 1980.
62. D. E. Hocevar and T. N. Trick, Automatic tuning algorithms for active filters, *IEEE Trans. Circuits Syst.*, vol. CAS-29, pp. 448–458, 1982.
63. W. Kellermann, Advances in optimization of circuits and systems using recent minimax and  $l_1$  algorithms, Ph.D. Thesis, McMaster Univ. Hamilton, Canada, 1986.
64. TOUCHSTONE, EEs of Inc., Westlake Village, Calif., 1985.
65. R. Saeks, A. Sangiovanni-Vincentelli, and V. Visvanathan, Diagnosability of nonlinear circuits and systems—part II: Dynamical systems, *IEEE Trans. Circuits Syst.*, vol. CAS-28, pp. 1103–1108, 1981.
66. A. T. Johnson, Jr., Efficient fault analysis in linear analog circuits, *IEEE Trans. Circuits Syst.*, vol. CAS-26, pp. 475–484, 1979.
67. H. S. M. Chen and R. Saeks, A search algorithm for the solution of the multifrequency fault diagnosis equations, *IEEE Trans. Circuits Syst.*, vol. CAS-26, pp. 589–594, 1979.

68. G. C. Temes, Efficient methods of fault simulation, *Proc. 20th Midwest Symp. Circuits Syst.*, Lubbock, Texas, pp. 191–194, 1977.
69. S. B. Haley and K. W. Current, Response change in linearized circuits and systems: Computational algorithms and applications, *Proc. IEEE*, vol. 73, pp. 5–24, 1985.
70. A. Groch, L. M. Vidigal, and S. W. Director, A new global optimization method for electronic circuit design, *IEEE Trans. Circuits Syst.*, vol. CAS-32, pp. 160–170, 1985.